

General Specifications

GS 32Q06K11-31E

Model SNT10D
Unit for Optical Bus Repeater
Module
(Rack Mountable Type)

ProSafe-RS

■ GENERAL

Unit for Optical Bus Repeater Module is a unit to install Optical ESB Bus Repeater Modules. There are two types of connection for the Unit: star type connection and chain type connection. The star type connection functions as a hub for ESB Bus.

■ STANDARD SPECIFICATIONS

For the installation requirements standards that are common throughout the system, refer to "ProSafe-RS Outline of I/O Modules (for FIO)" (GS 32P06K60-01EN).

● Power Supply Voltage

The power supply voltage is specified in the suffix codes.

Voltage: 100 to 120 V AC and 50/60 Hz frequency
Voltage: 220 to 240 V AC and 50/60 Hz frequency
Voltage: 24 V DC

● Power Consumption

100 to 120 V AC specification: 200 VA
220 to 240 V AC specification: 230 VA
24 V DC specification: 5.5 A

● Weight

Approx. 5.2 kg

● Mounting Method

Rack mounting: Rack mount with four M5 screws
Insulation bushes (accessories) are used.

● Conformity Standards

Refer to "ProSafe-RS Standard Compliant Models" (GS 32P01B60-01EN).

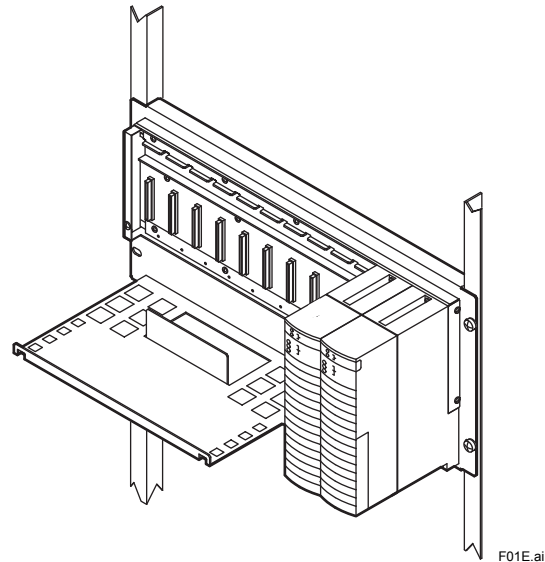

■ CONFIGURATION

● Module Configuration

Power supply module: Supplies power to Optical ESB Bus Repeater Modules

The power supply terminal uses M4 screws.

Optical ESB Bus Repeater Modules SNT401, SNT501, SNT411 or SNT511: Even number of modules for each models.

(Up to 10 modules in total)

■ RESTRICTIONS AND CAUTIONS FOR MOUNTING

Modules other than SNT401, SNT501, SNT411 and SNT511 cannot be mounted to Unit for Optical Bus Repeater Module.

For restrictions for mounting Optical ESB Bus Repeater Module, refer to "Optical ESB Bus Repeater Module (GS 32Q06L15-31E, GS 32Q06L16-31E)."

EXTERNAL DIMENSIONS

● SNT10D Unit for Optical ESB Bus Repeater Module

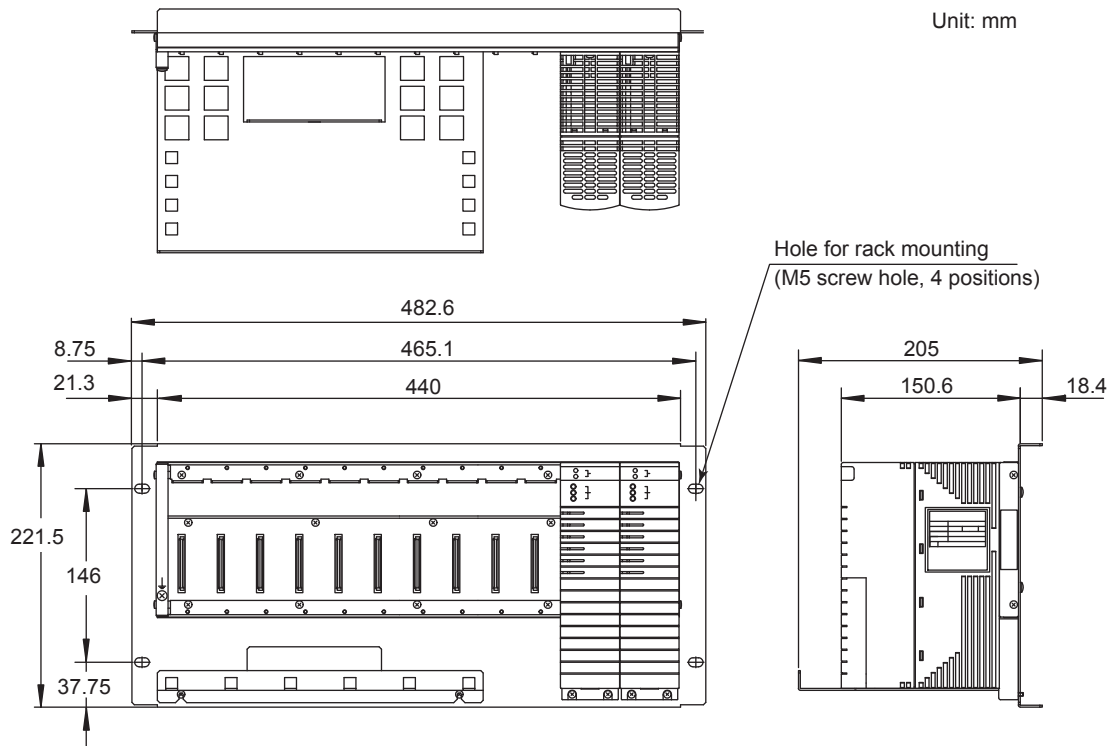

F02E.ai

Nominal Tolerances:

When the reference dimension is over 0.5 mm and equal or less than 120 mm, its nominal tolerance is ± 0.8 mm, while its combination of nominal tolerance is ± 1.5 mm.

When the reference dimension is over 120 mm, its nominal tolerance is in accordance with JEM 1459.

MODEL AND SUFFIX CODES

Unit for Optical Bus Repeater Module

		Description
Model	SNT10D	Unit for Optical Bus Repeater Module
Suffix Codes	-2	Dual-redundant power supply module
	1	100 to 120 V AC power supply
	2	220 to 240 V AC power supply
	4	24 V DC power supply
	5	ISA Standard G3 and temperature (-20 to 70 °C) with no explosion protection
	E	ISA Standard G3 and temperature (-20 to 70 °C) with explosion protection
Option Code	/ATDOC	Explosion Protection Manual

Note: Select the option code "/ATDOC" to follow the ATEX Directive for use in potentially explosive atmospheres.

Note: Install the 19-inch rack mountable type devices in a keyed metallic cabinet to conform to the safety standards, the EMC conformity standards and the explosion protection standards.

Dummy cover

		Description
Model	SDCV01	Dummy cover (for I/O modules)

Note: Be sure to mount a dummy cover on a slot that is not mounted with Optical ESB Bus Repeater module.

■ STANDARD ACCESSORIES

The unit for optical bus repeater module is supplied with the following accessory.

Accessory	Part number	Description	Quantity	Remark
Insulating bushing	S9049PM	SNT10D	4	Accessory

■ ORDERING INFORMATION

Specify the model and suffix codes when ordering.

For selecting the right products for explosion protection, please refer to TI 32S01J30-01E without fail.

■ TRADEMARKS

- ProSafe is a registered trademark of Yokogawa Electric Corporation.
- Other company and product names appearing in this document are trademarks or registered trademarks of their respective holders.