

SIEMENS

SIMATIC TDC

SIMATIC TDC hardware

System Manual

Industrial Cybersecurity

1

Installation and EMC
guidelines

2

General technical
specifications

3

Rack

4

CPU modules

5

Signal modules

6

Communication modules

7

Interface module

8



Submodules

9

Legal information

Warning notice system

This manual contains notices you have to observe in order to ensure your personal safety, as well as to prevent damage to property. The notices referring to your personal safety are highlighted in the manual by a safety alert symbol, notices referring only to property damage have no safety alert symbol. These notices shown below are graded according to the degree of danger.

 DANGER
indicates that death or severe personal injury will result if proper precautions are not taken.
 WARNING
indicates that death or severe personal injury may result if proper precautions are not taken.
 CAUTION
indicates that minor personal injury can result if proper precautions are not taken.
NOTICE
indicates that property damage can result if proper precautions are not taken.

If more than one degree of danger is present, the warning notice representing the highest degree of danger will be used. A notice warning of injury to persons with a safety alert symbol may also include a warning relating to property damage.

Qualified Personnel

The product/system described in this documentation may be operated only by **personnel qualified** for the specific task in accordance with the relevant documentation, in particular its warning notices and safety instructions. Qualified persons are those who, because of their training and experience, are familiar with the installation, assembly, commissioning, operation, decommissioning and disassembly of the product and can recognize risks and avoid possible hazards.

Proper use of Siemens products

Note the following:

 WARNING
Siemens products may only be used for the application described in the catalog and the associated usage information. If products and components from other manufacturers are used, these must be recommended or approved by Siemens. Proper transport, storage, installation, assembly, commissioning, operation and maintenance are required to ensure that the products operate safely and without any problems. The permissible ambient conditions must be complied with. The information in the relevant documentation must be observed.

Trademarks

All names identified by ® are registered trademarks of Siemens Aktiengesellschaft. The remaining trademarks in this publication may be trademarks whose use by third parties for their own purposes could violate the rights of the owner.

Disclaimer of Liability

We have reviewed the contents of this publication to ensure consistency with the hardware and software described. Since variance cannot be precluded entirely, we cannot guarantee full consistency. However, the information in this publication is reviewed regularly and any necessary corrections are included in subsequent editions.

Preface

Purpose of this manual

This manual describes the principles of using the functions of the hardware components, while setting the focus on the corresponding Technology and Drive Control components SIMATIC TDC.

Basic knowledge required

This manual is intended for commissioning personnel. Comprehension of this manual requires general knowledge of automation engineering.

Scope of the manual

This manual is valid for SIMATIC D7-SYS as of version 10.0.

Position in the information landscape

This manual is part of the documentation package for the Technology and Drive Control components FM 458, SIMATIC TDC and SIMATIC D7-SYS.

Title	Contents
System and Communication Configuration D7-SYS (http://support.automation.siemens.com/WW/view/de/8776461/0/en)	Just a few steps away from the first project This section provides an extremely simple introduction into the methodology of the structure and programming of the SIMATIC TDC control system. It is interesting especially for first-time users. System software This section communicates basic knowledge of the structure of a CPU's operating system and application programs. It should be used under the aspect of obtaining an overview of programming methodology and using this information as a basis for designing user programs. Configuring communication This section communicates basic knowledge of the communication possibilities and how to configure links to communication partners.
D7-SYS - STEP 7, configuring CFCs and SFCs (http://support.automation.siemens.com/WW/view/de/8776786/0/en)	Basic software This section explains the principles of use and functions of the STEP 7 automation software. Beginners obtain an overview of the procedures to follow when configuring, programming, and commissioning a station. While working with the basic software, you can directly rely on the Online Help system that offers support when it comes to detailed questions on using the software. CFC The CFC language (Continuous Function Chart) offers you the possibility of designing graphic interconnections for blocks.

Title	Contents
	<p>While working with the particular software, you can always consult the Online Help to get answers to detailed questions regarding the use of the editors/compiler.</p> <p>SFC Configuring sequential controls using SIMATIC S7 SFCs (sequential function chart). You create the sequential chart in the SFC Editor based on various graphic resources and position the SFC elements of the chart according to defined rules.</p>
Hardware	These manuals form a reference for the entire hardware spectrum.
D7-SYS Selecting function blocks http://support.automation.siemens.com/WW/view/de/1495240-0/0/en	<p>The Reference Manual provides you with an overview of all of the function blocks for the corresponding Technology and Drive Control components SIMATIC TDC, FM 458-1 DP as well as the T400 and SIMADYN D systems which are being phased out.</p> <p>Section 1 This section describes the function blocks that can be configured in all target systems of SIMATIC D7-SYS.</p> <p>Section 2 This section describes the function blocks that can be configured only for SIMATIC TDC.</p> <p>Section 3 This section describes the function blocks that can be configured only for the FM 458-1 DP application module.</p> <p>Section 4 This section describes the function blocks that can be configured only for SIMADYN D and T400.</p>

Signpost

As first-time user, you should use the manual as follows:

- Read the initial sections before using the software so that you become familiar with the terminology and procedural principles.
- You can then go ahead and use the respective sections of the manual, for example, if you intend to run a specific task (e.g. loading programs).

If you have already gained some experience while running a small project, you can read individual sections of the manual in order to obtain information on specific topics.

Special notes

The objective of the user part of this manual is to provide information on basic procedures, but does not contain any detailed instructions with individual step sequences. For more information on the software dialogs and their handling, refer to the Online Help.

Data protection

Siemens respects the principles of data privacy, in particular the data minimization rules (privacy by design). For this SIMATIC product, this means: The product does not process or store any personal data, only technical function data (e.g. time stamps). If a user links this data with other data (e.g. shift schedules) or stores personal data on the same storage medium (e.g. hard disk), and thus establishes a link to a person or persons, then the user is responsible for ensuring compliance with the relevant data protection regulations.

Recycling and disposal

For environmentally friendly recycling and disposal of your old equipment, contact a certified electronic waste disposal company and dispose of the equipment according to the applicable regulations in your country.

Additional support

You can find the offer for technical documentation for the individual SIMATIC products and systems on the Internet (<http://www.siemens.com/simatic-tech-doku-portal>).

SiePortal

You can find current information on the following topics quickly and easily here:

- **Catalog and ordering system**
Ordering system for automation and drive solutions based on Totally Integrated Automation (TIA) and Totally Integrated Power (TIP).
- **Product support**
All the information and extensive know-how on your product, technical specifications, FAQs, certificates, downloads, and manuals.
- **Application examples**
Tools and examples to solve your automation tasks – as well as function blocks, performance information and videos.
- **Services**
Information about Industry Services, Field Services, Technical Support, spare parts and training offers.
- **Forums**
For answers and solutions concerning automation technology.
- **mySiePortal**
Your personal work area in the SiePortal for notifications, support requests, and configurable documents.

This information provides you SiePortal on the Internet (<https://sieportal.siemens.com>).

Open Source Software

Open-source software is used in the firmware of the product described. Open Source Software is provided free of charge. We are liable for the product described, including the open-source software contained in it, pursuant to the conditions applicable to the product. Siemens accepts no liability for the use of the open source software over and above the intended program sequence, or for any faults caused by modifications to the software.

For legal reasons, we are obliged to publish the original text of the license conditions and copyright notices.

You can find this information on the supplied CD/DVD.

Table of contents

1	Industrial Cybersecurity.....	12
1.1	Security information.....	12
2	Installation and EMC guidelines.....	13
2.1	Qualified personnel.....	13
2.2	Danger and warning information.....	14
2.3	Introduction.....	14
2.4	Standards, approvals and safety instructions.....	15
2.5	EMC Directive.....	20
2.6	Low-voltage directive.....	21
2.7	Machinery directive.....	21
2.8	Installation.....	21
2.9	Fire protection.....	22
2.10	Control cabinet.....	24
2.11	Equipotential bonding.....	26
2.12	Protective ground.....	32
2.13	Power losses in the control cabinet.....	33
2.14	Power supply.....	34
2.15	Rack.....	35
2.16	Cables.....	36
2.17	ESD Directives.....	38
3	General technical specifications.....	41
3.1	Climatic conditions.....	41
3.2	Electrical protection and safety requirements.....	41
3.3	External supply of the SIMATIC TDC modules (digital outputs).....	42
3.4	Mechanical requirements.....	42
3.5	Electromagnetic requirements (industry).....	42
4	Rack.....	43
4.1	Rack UR6021 (6DD1682-0CH3).....	43
4.1.1	Areas of application.....	43
4.1.2	Mechanical layout.....	44
4.1.3	Control and display elements.....	45

4.1.4	Status and fault displays.....	46
4.1.5	Power supply.....	47
4.1.6	Wiring diagram.....	48
4.1.7	Voltage monitoring.....	48
4.1.8	Battery backup.....	50
4.1.9	Modules.....	51
4.1.10	Power supply potentials.....	51
4.1.11	Ventilation/cooling.....	52
4.1.12	Technical specifications.....	55
4.2	Rack UR5213 (6DD1682-0CH2).....	57
4.2.1	Areas of application.....	57
4.2.2	Mechanical layout.....	58
4.2.3	Control and display elements.....	59
4.2.4	Status and fault displays.....	60
4.2.5	Power supply.....	60
4.2.6	Wiring diagram.....	61
4.2.7	Voltage monitoring.....	61
4.2.8	Battery backup.....	63
4.2.9	Modules.....	64
4.2.10	Power supply potentials.....	64
4.2.11	Ventilation/cooling.....	65
4.2.12	Technical specifications.....	66
4.3	Rack UR5213 (6DD1682-0CH0).....	68
4.3.1	Areas of application.....	68
4.3.2	Mechanical layout.....	69
4.3.3	Control and display elements.....	69
4.3.4	Status and fault displays.....	70
4.3.5	Power supply.....	71
4.3.6	Voltage monitoring.....	71
4.3.7	Battery backup.....	72
4.3.8	Ventilation/cooling.....	73
4.3.9	Technical specifications.....	74
4.4	Slot covers.....	75
5	CPU modules.....	76
5.1	CPU module CPU555.....	76
5.1.1	Areas of application.....	76
5.1.2	Control and display elements.....	77
5.1.3	Status and fault displays.....	78
5.1.4	Application notes and immunity to interference.....	81
5.1.5	Connection options.....	82
5.1.6	Additional components.....	82
5.1.7	Pin assignments.....	83
5.1.8	Note on firmware update.....	83
5.1.9	Using CPU555 firmware V1.1.....	84
5.1.10	Technical specifications/performance features.....	85
5.2	CPU module CPU550/CPU551.....	88

5.2.1	Areas of application.....	88
5.2.2	Using the CPU551 - 6DD1600-0BA3.....	89
5.2.3	Control and display elements.....	90
5.2.4	Status and fault displays.....	91
5.2.5	Application notes and immunity to interference.....	93
5.2.6	Connection options.....	93
5.2.7	Additional components.....	94
5.2.8	Pin assignments.....	94
5.2.9	Technical specifications/performance features.....	95
6	Signal modules.....	100
6.1	SM500 signal module.....	100
6.1.1	Areas of application.....	100
6.1.2	Control and display elements.....	100
6.1.3	Status and fault displays.....	101
6.1.4	Application notes and immunity to interference.....	102
6.1.5	Connection options.....	102
6.1.6	Additional components.....	103
6.1.7	Incremental encoder input settings.....	103
6.1.8	Pin assignments.....	105
6.1.9	Technical specifications/performance features.....	110
6.2	SM500 DI/DQ signal module.....	115
6.2.1	Areas of application.....	115
6.2.2	Control and display elements.....	115
6.2.3	Status and fault displays.....	116
6.2.4	Application notes and immunity to interference.....	117
6.2.5	Connection options.....	117
6.2.6	Additional components.....	117
6.2.7	Pin assignments.....	118
6.2.8	Technical specifications/performance features.....	122
7	Communication modules.....	124
7.1	CP50M1 communication module.....	124
7.1.1	Areas of application.....	124
7.1.2	Control and display elements.....	125
7.1.3	Status and fault displays.....	126
7.1.4	Application notes and immunity to interference.....	127
7.1.5	Connection options.....	127
7.1.6	Additional components.....	128
7.1.7	Pin assignments.....	128
7.1.8	Technical specifications/performance features.....	129
7.2	CP51M1 communication module.....	131
7.2.1	Areas of application.....	131
7.2.2	Control and display elements.....	132
7.2.3	Status and fault displays.....	133
7.2.4	Application notes and immunity to interference.....	134
7.2.5	Connection options.....	134
7.2.6	Additional components.....	135
7.2.7	Pin assignments.....	135
7.2.8	Technical specifications/performance features.....	136

7.3	GDM memory module CP52M0.....	138
7.3.1	Areas of application.....	138
7.3.2	Control and display elements.....	139
7.3.3	Status and fault displays.....	140
7.3.4	Application notes and immunity to interference.....	142
7.3.5	Connection options.....	144
7.3.6	Additional components.....	145
7.3.7	Pin assignments.....	145
7.3.8	Technical specifications/performance features.....	147
7.4	CP52IO GDM interface module.....	149
7.4.1	Areas of application.....	149
7.4.2	Control and display elements.....	150
7.4.3	Status and fault displays.....	151
7.4.4	Application notes and immunity to interference.....	152
7.4.5	Connection options.....	153
7.4.6	Additional components.....	153
7.4.7	Pin assignments.....	154
7.4.8	Technical specifications/performance features.....	154
7.5	CP52A0 GDM access module.....	155
7.5.1	Areas of application.....	155
7.5.2	Using the CP52A0 - 6DD1660-0BH1.....	155
7.5.3	Control and display elements.....	156
7.5.4	Status and fault displays.....	157
7.5.5	Application notes and immunity to interference.....	158
7.5.6	Connection options.....	159
7.5.7	Additional components.....	159
7.5.8	Pin assignments.....	160
7.5.9	Technical specifications/performance features.....	160
7.6	CP53M0 coupling module.....	161
7.6.1	Areas of application.....	161
7.6.1.1	CP53M0 as slave.....	161
7.6.1.2	CP53M0 as master.....	162
7.6.2	Control and display elements.....	164
7.6.3	Status and fault displays.....	165
7.6.4	Application notes and immunity to interference.....	167
7.6.5	Connection options.....	168
7.6.6	Additional components.....	168
7.6.7	Pin assignments.....	169
7.6.8	Technical specifications/performance features.....	169
8	Interface module.....	171
8.1	Interface module SB10.....	171
8.1.1	Signals.....	173
8.1.2	Application notes.....	174
8.1.3	Technical specifications.....	174
8.1.4	Pin assignment.....	175
8.1.5	Block diagram.....	176

8.2	Interface module SB60.....	177
8.2.1	Signals.....	179
8.2.2	Application notes.....	179
8.2.3	Technical specifications.....	179
8.2.4	Pin assignment.....	180
8.2.5	Block diagram.....	181
8.3	Interface module SB61.....	182
8.3.1	Signals.....	183
8.3.2	Application notes.....	184
8.3.3	Technical specifications.....	186
8.3.4	Pin assignment.....	187
8.3.5	Block diagram.....	188
8.4	Interface module SB70.....	189
8.4.1	Signals.....	191
8.4.2	Application notes.....	192
8.4.3	Technical specifications.....	192
8.4.4	Pin assignment.....	193
8.4.5	Block diagram.....	194
8.5	Interface module SB71.....	195
8.5.1	Signals.....	197
8.5.2	Application notes.....	198
8.5.3	Technical specifications.....	199
8.5.4	Pin assignment.....	200
8.5.5	Block diagram.....	201
8.6	Interface modules SU12 und SU13.....	202
8.6.1	Function description.....	203
8.6.2	Additional components.....	204
8.6.3	Application notes.....	204
8.6.4	Pin/terminal assignment X1/X2.....	205
8.6.5	Technical specifications.....	206
9	Submodules.....	207
9.1	Program memory modules CPU555.....	207
9.2	Program memory modules CPU550/551.....	208
	Index.....	210

Industrial Cybersecurity

1.1 Security information

Siemens provides products and solutions with industrial cybersecurity functions that support the secure operation of plants, systems, machines and networks.

In order to protect plants, systems, machines and networks against cyber threats, it is necessary to implement – and continuously maintain – a holistic, state-of-the-art industrial cybersecurity concept. Siemens' products and solutions constitute one element of such a concept.

Customers are responsible for preventing unauthorized access to their plants, systems, machines and networks. Such systems, machines and components should only be connected to an enterprise network or the Internet if and to the extent such a connection is necessary and only when appropriate security measures (e.g. firewalls and/or network segmentation) are in place.

Additional information on industrial cybersecurity measures can be found at (<http://www.siemens.com/cybersecurity-industry>).

Siemens' products and solutions undergo continuous development to make them more secure. Siemens expressly recommends that product updates be applied as soon as they become available and that only the latest product versions be used. Use of product versions that are no longer supported, and failure to apply latest updates may increase customer's exposure to cyber threats.

To stay informed about product updates, subscribe to the Siemens Industrial Cybersecurity RSS Feed at (<https://www.siemens.com/cert>).

Installation and EMC guidelines

NOTE

These Operating Instructions do not purport to cover all details or variations in equipment, nor to provide for every possible contingency to be met in connection with installation, operation or maintenance.

If you need further information or encounter special problems that are not adequately treated in the operating instructions, you can obtain the necessary information from your local Siemens office.

Furthermore, the contents of these Operating Instructions shall not become a part of or modify any prior or existing agreement, commitment, or legal relationship. All obligations on the part of Siemens AG are contained in the respective sales contract which also contains the complete and solely applicable warranty conditions. These contractual guarantee provisions are neither broadened nor restricted by the text in these operating instructions.

2.1 Qualified personnel

in the context of the operating manual or of warning notices on the product itself are persons familiar with installation, assembly, commissioning and operation of the product and holding qualifications appropriate to their activity, such as:

1. Trained and authorized to power up, shut down, ground and tag electrical circuits and equipment in accordance with safety standards.
2. Trained in the proper care and use of protective equipment in accordance with safety standards.

2.2 Danger and warning information



⚠ WARNING

Danger, high voltage

During operation of electrical devices, certain parts of these devices are necessarily under dangerous voltage.

Ignorance of the safety instructions may result in severe injury or property damage.

Particularly the warning notes in the corresponding Operating Instructions must be strictly observed.

NOTICE

Electrostatic sensitive devices

The modules contain components that are sensitive to electrostatic charge. Always discharge your body before you touch an electronic module. This can be done quite simply by touching a conductive, grounded object immediately before you handle the component (e.g. bright metal parts of the control cabinet, grounding contact of socket outlet.)

NOTICE

Lifting and carrying heavy loads

Note the regulations/notes on lifting and carrying heavy loads.

NOTICE

Cleaning the devices

Use only a vacuum cleaner and dry cloths to clean the devices.

2.3 Introduction

What is EMC ?

Electromagnetic compatibility (EMC) is the ability of an electrical device to function, fault-free in a specified electromagnetic environment without influencing the environment in an inadmissible fashion.

This design and EMC Directive supplements the documentation on the individual components.

The SIMATIC TDC control system consists of individual components (e.g. racks, modules, interface modules, operator control panels, position transmitters). The components can be installed in the widest range of system configurations to suit individual requirements. In an environment that contains distributed components it is imperative not to neglect interference and to conform with special installation and EMC requirements of the plant.

EMC therefore represents a quality feature for

- **Intrinsic immunity to interference:** Resistance against internal electrical disturbance variables
- **Immunity to external interference:** Resistance of the system against external electromagnetic disturbance variables
- **Degree of interference emission:** Environmental effects caused by electromagnetic radiation

Operational reliability and immunity to interference

The manufacturer of the control system and users (including end customers) must take specific measures in order to achieve the maximum possible operational reliability and safety and interference immunity for a complete system (control and drive system).

Proper functioning of SIMATIC TDC can only be ensured if all of these measures have been observed in compliance with legal provisions (2014/30/EU).

2.4 Standards, approvals and safety instructions

Currently valid markings and authorizations

NOTE

Information on the components of the SIMATIC TDC

The valid marks and approvals are printed on the components of the SIMATIC TDC.

Safety information

 WARNING
Personal injury and damage to property may occur
In potentially explosive atmospheres, personal injury and material damage can be incurred if plug connections are disconnected during operation of the SIMATIC TDC.
Always de-energize the SIMATIC TDC in hazardous areas to disconnect plug connections.

 WARNING
Explosion hazard
If you replace components, compliance with Class I, DIV 2 may become invalid.

⚠ WARNING
Deployment requirements This device is only suitable for use in Class I, Div. 2, Group A, B, C, D, or in non-hazardous areas.

Safety of the plant or the system

NOTICE
Safety is the responsibility of the assembler The safety of any plant or system incorporating the equipment is the responsibility of the assembler of the plant or system.

CE mark



Our products meet the requirements and protection objectives of the EU Directives listed below and comply with Harmonized European Standards (EN) for programmable controllers that were published in the Official Journals of the European Union:

- 2014/35/EU "Electrical equipment designed for use within certain voltage limits" (Low-Voltage Directive)
- 2014/30/EU "Electromagnetic Compatibility" (EMC Directive)
- 2014/34/EU "Equipment and protective systems intended for use in potentially explosive atmospheres" (Explosion Protection Directive)
- 2011/65/EU "Restriction of the use of certain hazardous substances in electrical and electronic equipment" (RoHS Directive)

EU declarations of conformity for the respective authorities are available from:

Siemens AG
Digital Industries
Factory Automation
DI FA TI COS TT
P.O. Box 1963
D-92209 Amberg

The EU declarations of conformity are also available for download from the Siemens Industry Online Support website, under the keyword "Declaration of Conformity".

UK Conformity Assessed marking

The SIMATIC TDC complies with the designated British Standards (BS) for programmable logic controllers published in the official consolidated list of the British Government. The SIMATIC TDC meets the requirements and protection targets of the following regulations and related amendments:

- Electrical Equipment (Safety) Regulations 2016 (Low-Voltage)
- Electromagnetic Compatibility Regulations 2016 (EMC)
- Equipment and Protective Systems Intended for use in Potentially Explosive Atmospheres Regulations 2016 (Explosion Protection)
- Regulations on the restriction of the use of certain hazardous substances in electrical and electronic equipment 2012 (RoHS).

UK Declarations of Conformity for the respective authorities are available from:

Siemens AG
 Digital Industries
 Factory Automation
 DI FA TI COS TT
 P.O. Box 1963
 D-92209 Amberg

The UK Declaration of Conformity is also available for download from the Siemens Industry Online Support website under the keyword "Declaration of Conformity".

cULus approval

Underwriters Laboratories Inc. in accordance with

- UL 508 (Industrial Control Equipment)
- CAN/C22.2 No. 142 (Process Control Equipment)

OR

cULus HAZ. LOC. approval

HAZ. LOC.

Underwriters Laboratories Inc. in accordance with

- UL 508 (Industrial Control Equipment)
- CANCSA C22.2 No. 142 (Process Control Equipment)
- ANSI/ISA 12.12.01
- CAN/CSA C22.2 No. 213 (Hazardous Location)

APPROVED for use in
 Class I, Division 2, Group A, B, C, D T4;
 Class I, Zone 2, Group IIC T4

Installation Instructions for cULus haz.loc.

- WARNING – Explosion Hazard – Do not disconnect while circuit is live unless area is known to be non-hazardous.
- WARNING – Explosion Hazard – Substitution of components may impair suitability for Class I, Division 2 or Zone 2.
- This equipment is suitable for use in Class I, Division 2, Groups A, B, C, D; Class I, Zone 2, Group IIC; or non-hazardous locations.

FM approval



Factory Mutual Research (FM) according to

- Approval Standard Class Number 3611, 3600, 3810

APPROVED for use in Class I, Division 2, Group A, B, C, D T4A;
Class I, Zone 2, Group IIC T4

Installation Instructions for FM

- WARNING – Explosion Hazard – Do not disconnect while circuit is live unless area is known to be non-hazardous.
- WARNING – Explosion Hazard – Substitution of components may impair suitability for Class I, Division 2 or Zone 2.
- This equipment is suitable for use in Class I, Division 2, Groups A, B, C, D; Class I, Zone 2, Group IIC; or non-hazardous locations.

ATEX approval



According to EN 60079-15 (Explosive atmospheres - Part 15: Equipment protection by type of protection "n") and EN IEC 60079-0 (Explosive atmospheres - Part 0: Equipment - General Requirements).

II 3 G Ex nA IIC T4 Gc
DEKRA 17ATEX0079 X

OR

According to EN IEC 60079-7 +A1 (Explosive atmospheres - Part 7: Equipment protection by increased safety "e") and EN IEC 60079-0 (Explosive atmospheres - Part 0: Equipment - General requirements).

II 3 G Ex ec IIC T4 Gc
DEKRA 21ATEX0049 X

Special conditions in hazardous area:

1. The equipment shall only be used in an area of not more than degree of pollution 2, as defined in EN 60664-1.
2. The equipment shall be installed in a suitable enclosure providing a degree of protection not less than IP54 in accordance with EN IEC 60079-0. The ambient conditions must be taken into consideration for use.
3. Provisions shall be made to prevent the nominal voltage from being exceeded by transient disturbance voltages of more than 119 V.

UKEX approval

According to EN IEC 60079-7 +A1 (Explosive atmospheres - Part 7: Equipment protection by increased safety "e") and EN IEC 60079-0 (Explosive atmospheres - Part 0: Equipment - General requirements).

II 3 G Ex ec IIC T4 Gc
DEKRA 21UKEX0012 X

Special conditions in explosive atmospheres:

1. The equipment shall only be used in an area of not more than degree of pollution 2, as defined in EN 60664-1.
2. The equipment shall be installed in a suitable enclosure providing a degree of protection not less than IP54 in accordance with EN IEC 60079-0. The ambient conditions must be taken into consideration for use.
3. Provisions shall be made to prevent the nominal voltage from being exceeded by transient disturbance voltages of more than 119 V.

IECEx approval

According to IEC 60079-15 (Explosive atmospheres - Part 15: Equipment protection by type of protection "n") and IEC 60079-0 (Explosive atmospheres - Part 0: Equipment - General requirements).

Ex nA IIC T4 Gc
IECEx DEK 17.0039 X

OR

According to IEC 60079-7 (Explosive atmospheres - Part 7: Equipment protection by increased safety "e") and IEC 60079-0 (Explosive atmospheres - Part 0: Equipment - General requirements).

Ex ec IIC T4 Gc
IECEx DEK 21.0031 X

Special conditions in hazardous areas:

1. The equipment shall only be used in an area of not more than degree of pollution 2, as defined in IEC 60664-1.
2. The device must be installed in a suitable enclosure providing a degree of protection not less than IP54 in accordance with IEC 60079-0. The ambient conditions must be taken into consideration for use.
3. Provisions shall be made to prevent the nominal voltage from being exceeded by transient disturbance voltages of more than 119 V.

CCCEX approval



In accordance with GB/T 3836.3 (Explosive atmospheres - Part 3: Equipment protection by increased safety "e") and GB/T 3836.1 (Explosive atmospheres - Part 1: Equipment - General requirements).

Ex ec IIC T4 Gc

Special conditions in hazardous areas:

- The equipment shall only be used in an area of not more than degree of pollution 2, as defined in GB/T 16935.1.
- The device must be installed in a suitable enclosure providing a degree of protection not less than IP54 in accordance with GB/T 3836.1. The ambient conditions must be taken into consideration for use.
- Provisions shall be made to prevent the nominal voltage from being exceeded by transient disturbance voltages of more than 119 V.

RCM Declaration of conformity for Australia/New Zealand



The SIMATIC TDC meets the requirements of the standard IEC 61000-6-4.

2.5 EMC Directive

SIMATIC products are designed for use in industrial environments.

Industrial area of application

- Interference emission requirements to EN 61000-6-4: 2007 + A1:2011
- Immunity to interference requirements to EN 61000-6-2: 2005

2.6 Low-voltage directive

The products listed in the table below fulfill the requirements of EU directive 2014/35/EU, "Low-Voltage Directive". Compliance with this EC directive was tested in accordance with DIN 61131-2 (corresponds to IEC 61131-2).

The following components are also affected in SIMATIC TDC:

Name	Article number
UR5213	6DD1682-0CH0
PS5213	6DD1683-0CH0
UR5213	6DD1682-0CH2
UR6021	6DD1682-0CH3
SB 60	6DD1681-0AF4
SB 70	6DD1681-0AG2
Fan tray	6DD1683-0CH3

These components are compliant with requirements of the Low-voltage Directive.

2.7 Machinery directive

In accordance with the Machinery Directive 2006/42/EC, it must be ensured that a failure or malfunction of SIMATIC TDC will not trigger a hazardous state of the machine/plant. This must always be taken into account when configuring the machine/system.

The system may not be commissioned until it has been proven that the final product is in compliance with the directive.

Expert personnel

Only expert personnel may configure, commission, service and operate SIMATIC TDC.

Input of external voltages

An external voltage source (e.g. pulse encoder) that is connected to SIMATIC TDC module inputs must be shut down simultaneously with the shutdown or failure of the SIMATIC TDC power supply.

2.8 Installation

SIMATIC TDC components are considered open equipment that must be installed in metallic enclosures containing shielding and equipotential busbars in compliance with the requirements of IEC 61131-2 (11.1.2; mechanical strength, flame resistance, stability and shock protection are significant here).

2.9 Fire protection

As output power exceeds the limit of circuitry with power limiting to IEC 61010-1 / IEC 61131-2, malfunction of a SIMATIC TDC component may pose the risk of fire according to IEC 61010-1 / IEC 61131-2. In order to prevent spreading of fire, suitable measures must be taken to prevent ignition of adjacent parts or components as a result of burning parts that possibly drop out of a component.

Two examples of a fire protection barrier to IEC 61010-1

Example 1

Partition below the rack

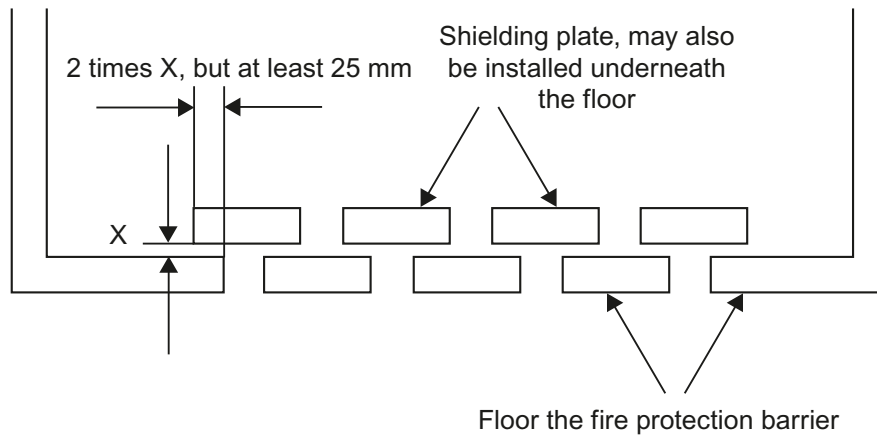

Example 2

Metal panel

Accepted perforation of a metal panel

Minimum thickness [mm]	Maximum diameter of the holes [mm]	Minimum hole pitch, center-center [mm]
0.76	1.1	1.7 (35 holes/100 mm ²)
0.76	1.2	2.4
0.89	1.9	3.2 (10 holes/100 mm ²)
0.99	1.6	2.7

Minimum size of the fire protection barrier

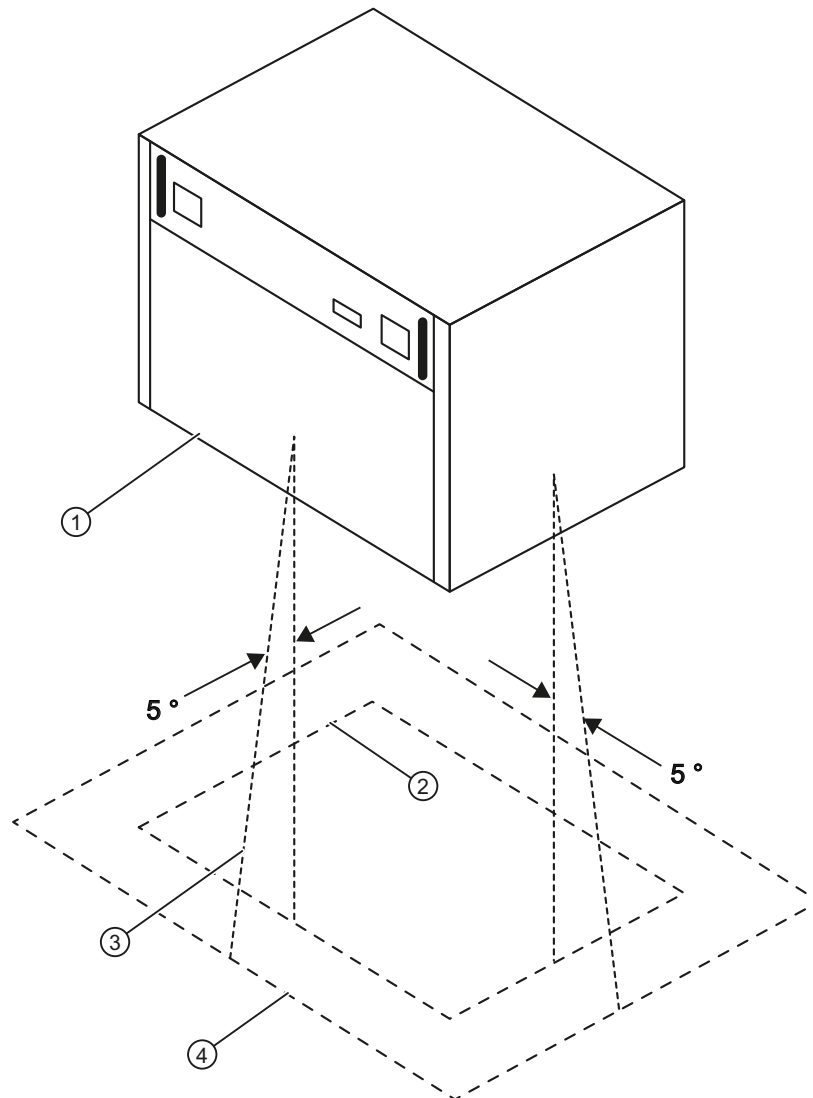

- ① Rack
- ② Vertical projection of the rack
- ③ +5° from the vertical projection profile
- ④ Minimum size of the barrier

2.10 Control cabinet

- All control cabinets must be equipped with a grounding/equipotential busbar that must be connected directly to the cabinet frame at both ends.
- It is not allowed to operate contactors without protective circuit in a control cabinet containing SIMATIC TDC components.
- If contactors without protective circuit are operated in a control cabinet next to the SIMATIC TDC cabinet, the cabinets must be partitioned by means of a sheet steel panel.
- All control cabinets in which SIMATIC TDC components are operated must be equipped with a shielding busbar that must be connected directly at both ends to the cabinet frame.
- It is not allowed to use gas discharge lamps in the cabinet.
- The cabinet must be designed to enable unobstructed air convection.

Arrangement and clearances

The following minimum dimensions must be maintained for stacked installations of SIMATIC TDC racks:

e.g. control cabinet 2200 x 600 x 600 mm

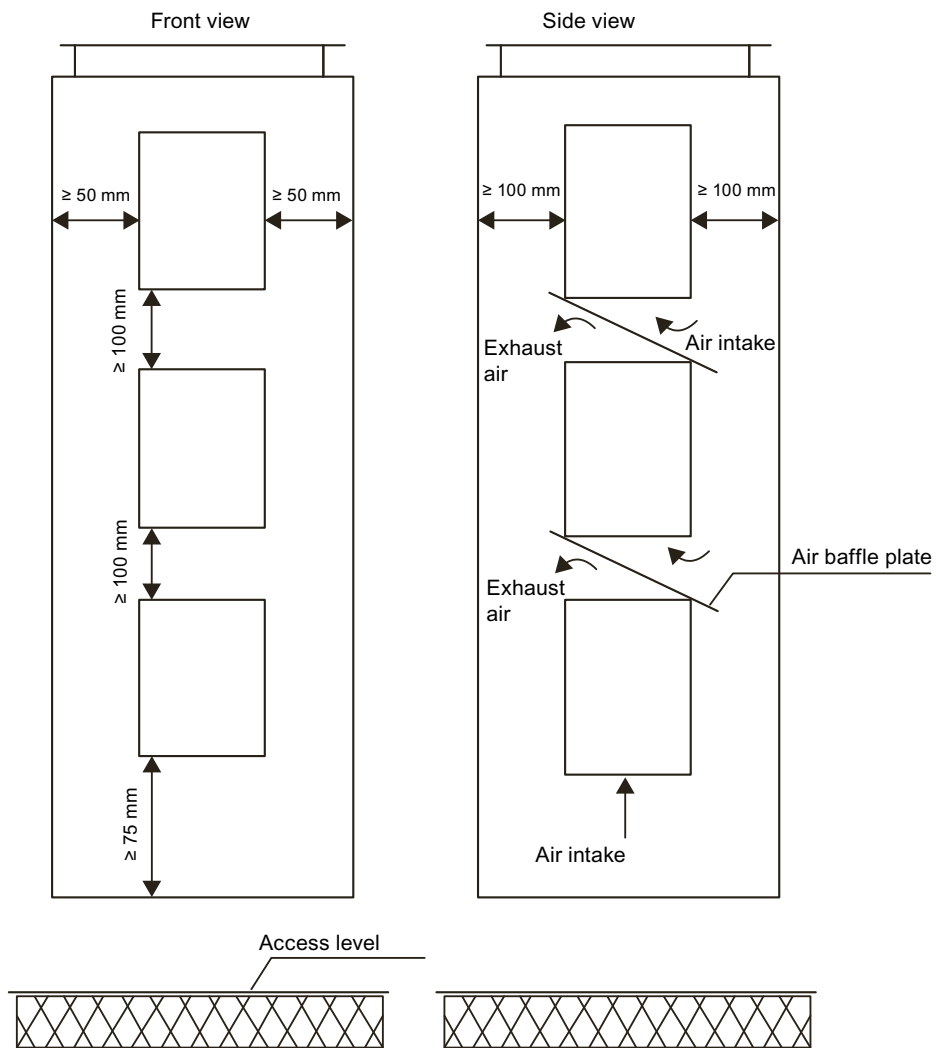

2.11 Equipotential bonding

In order to ensure disturbance-free operation, the networked components may not develop different potentials. For this reason, all components must be interconnected by means of equipotential bonding with a minimum cross-section of 16 mm².

Principle of the connection

All components (racks, power supplies, etc.) that are connected by signal cables must also be interconnected by means of equipotential bonding (exception: components with fiber-optic connections).

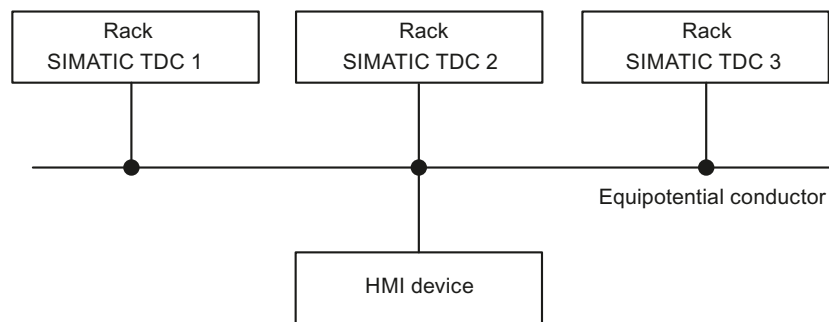

Equipotential busbar

An equipotential busbar should be provided in each control cabinet to facilitate wiring.

All internal and external components must be interconnected with this equipotential busbar.

Schematic circuit diagram

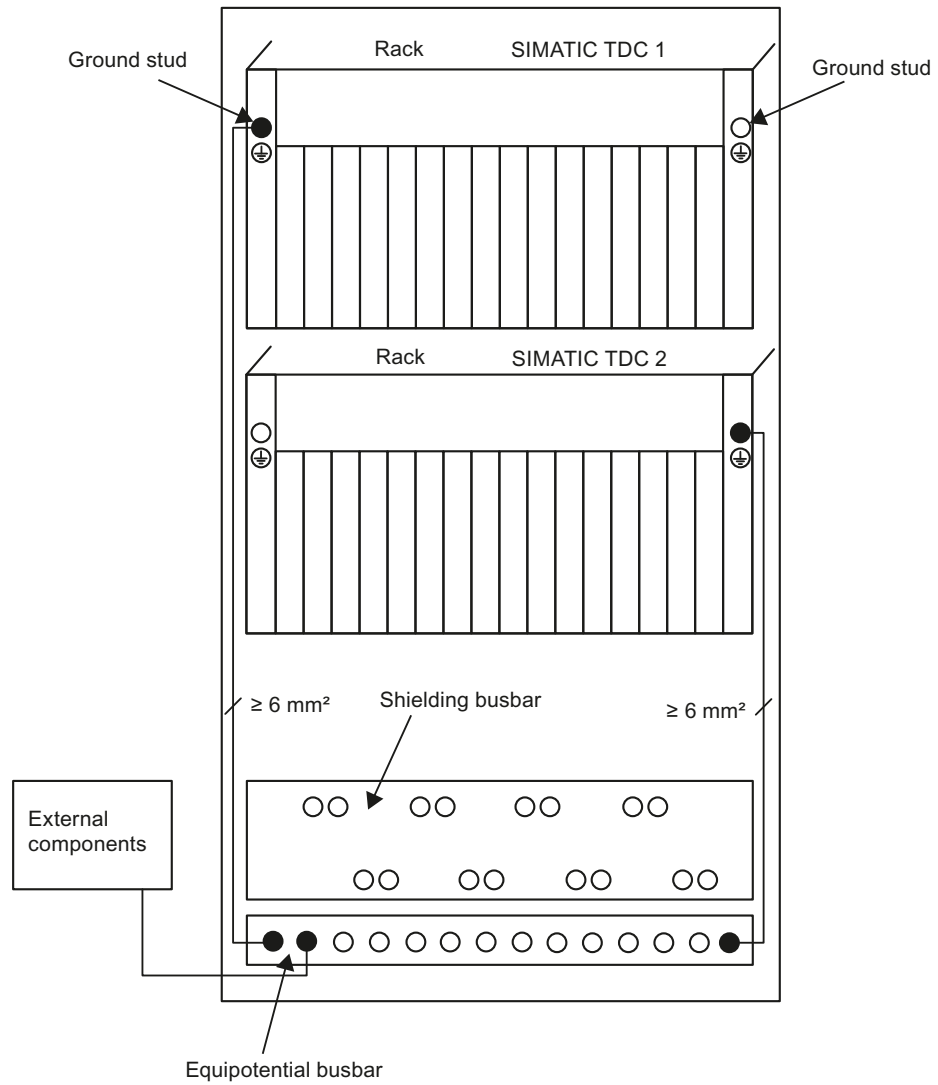

Practical application examples

Termination of an external shielded cable

The shield must be connected to the shielding bus.

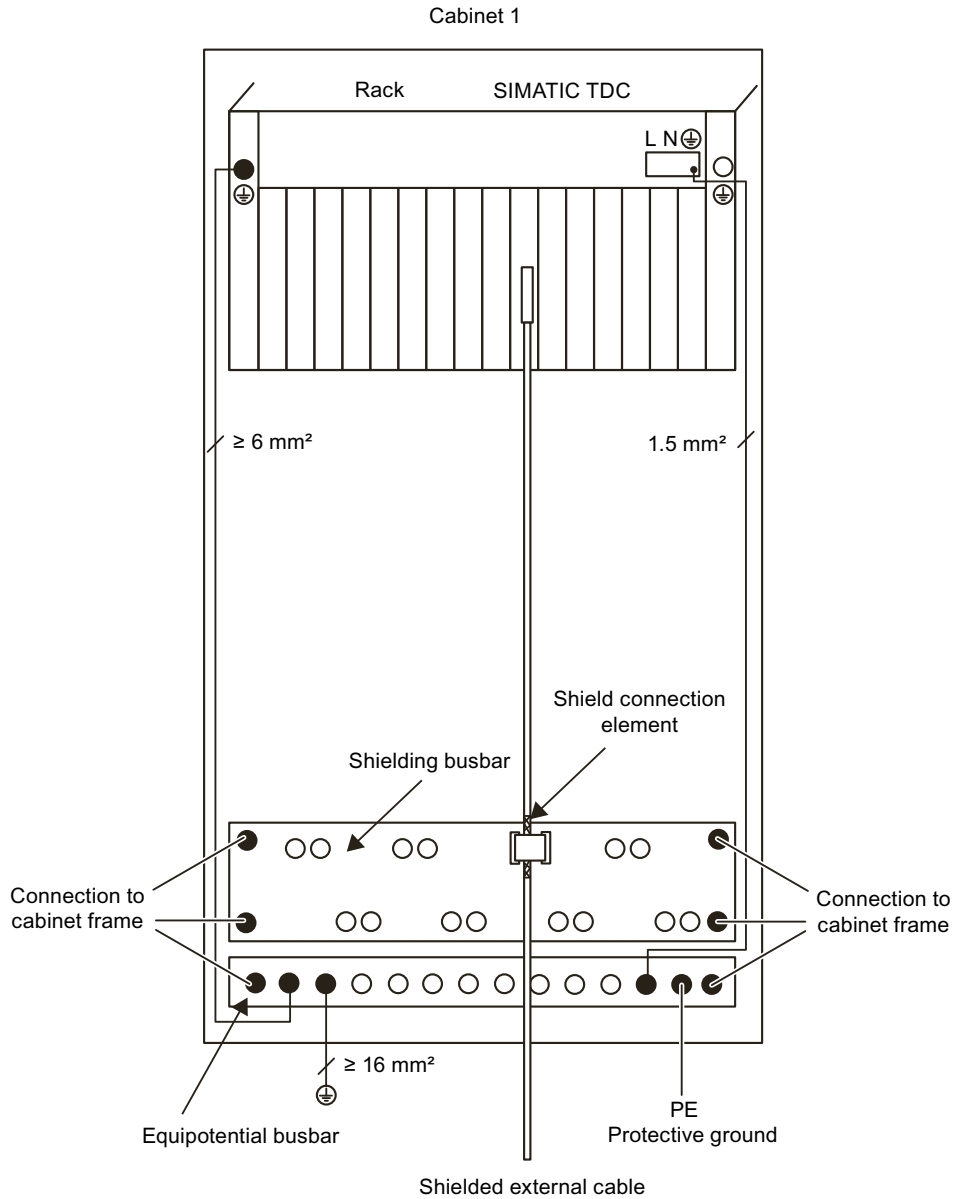

Termination of an external shielded cable with supply via interface module

The shield must be connected to the shielding bus.

Ground of the external power supply must be wired to the shielding busbar, or to the equipotential busbar.

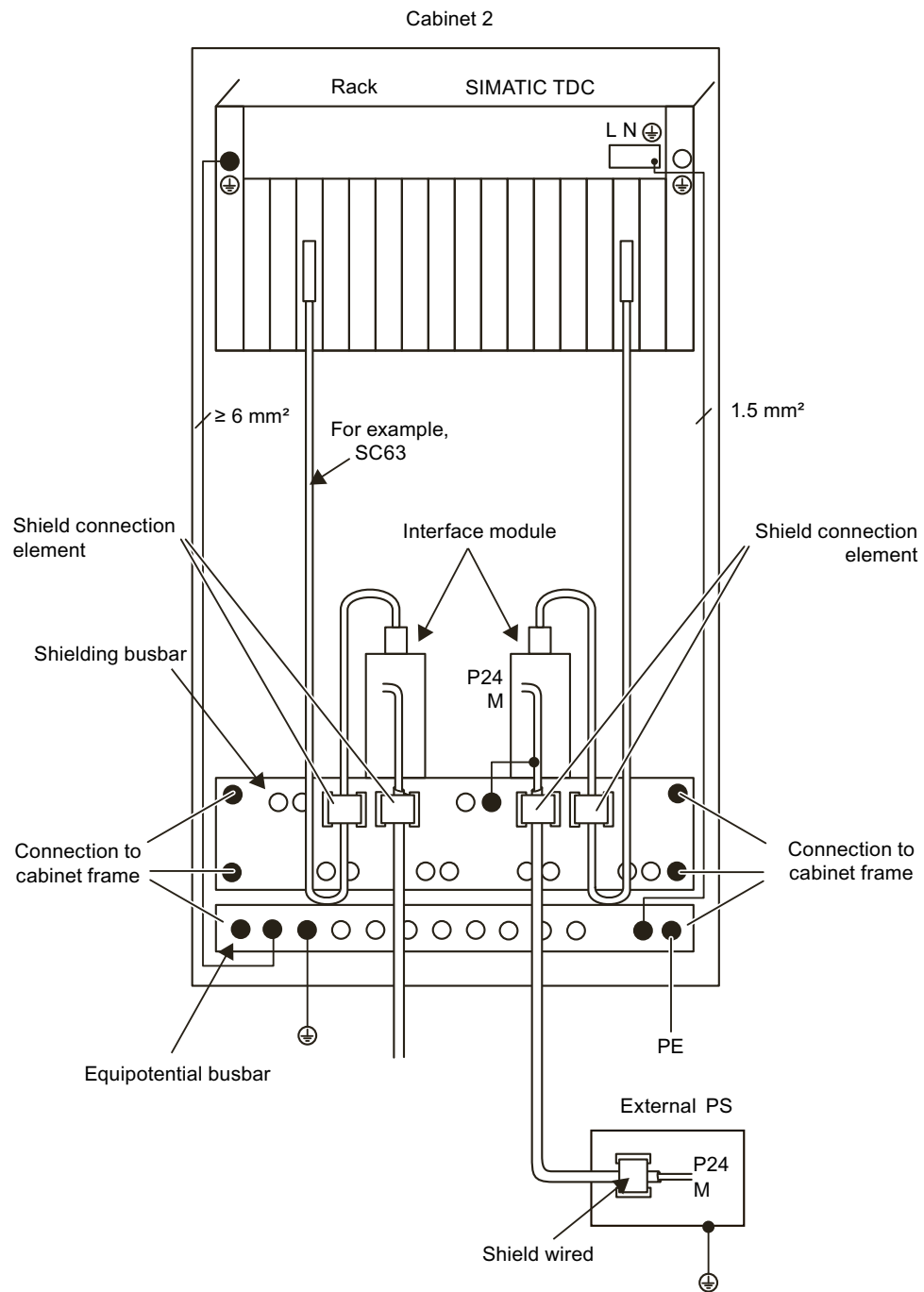

Termination of an internal power supply via interface module

The shield must be connected to the shielding bus.

2.11 Equipotential bonding

Ground of the internal power supply must be connected to the shielding busbar, or to the equipotential busbar.

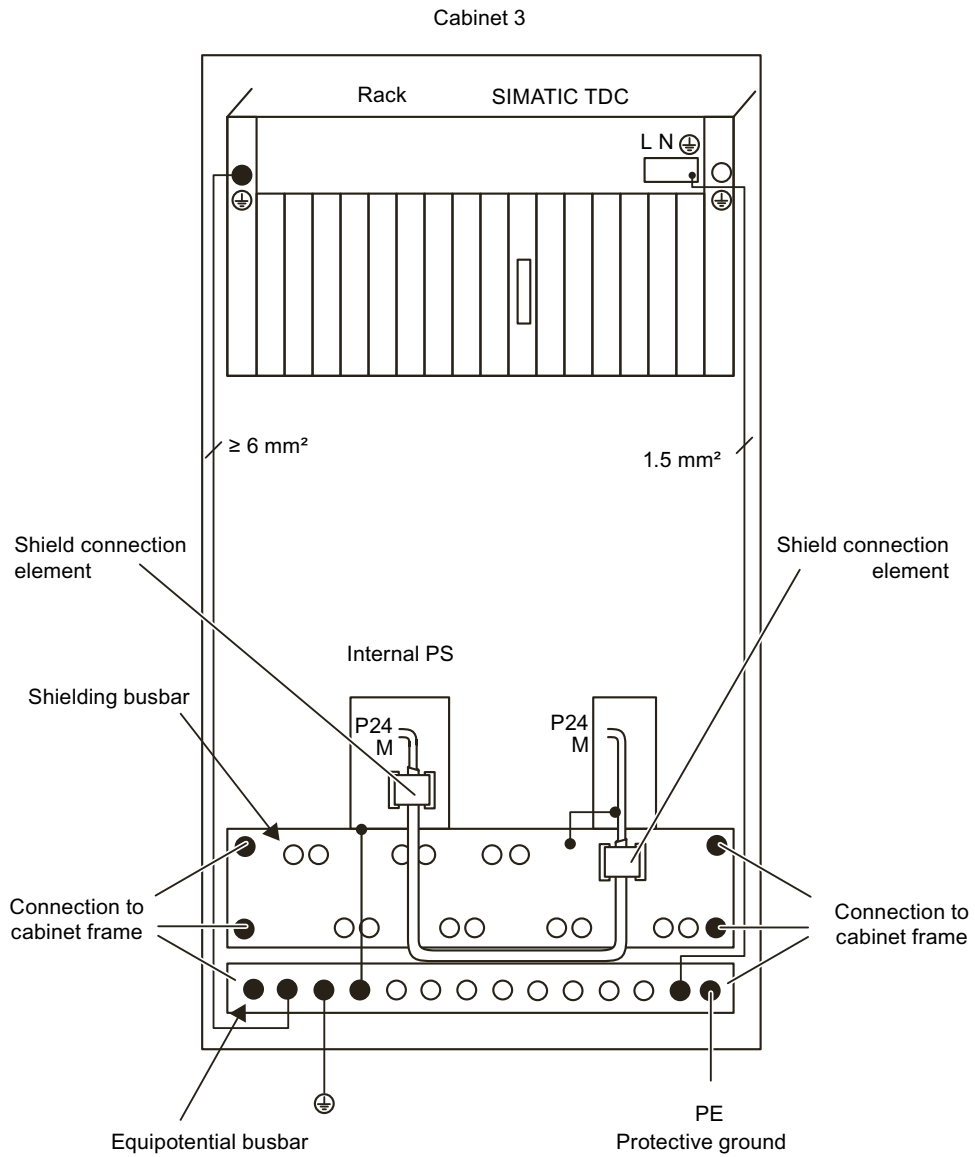

Example of grounding and potential equalization

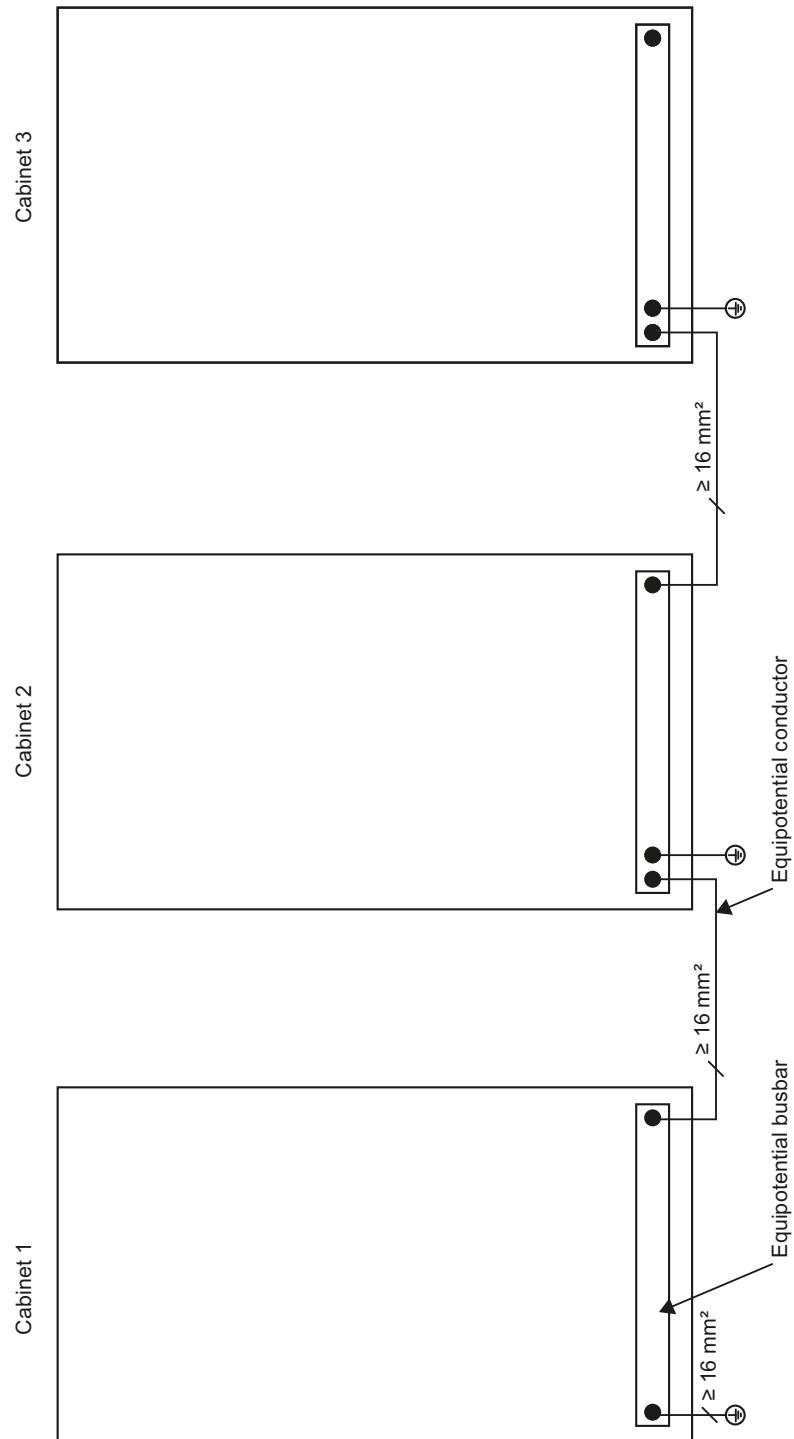

2.12 Protective ground

Protective ground is bonded to the cabinets or components via PE conductor. It is required in SIMATIC TDC for safe operation and as interference suppression measure.

The protective conductor must be routed and dimensioned in accordance with IEC 61131-2 (11.9).

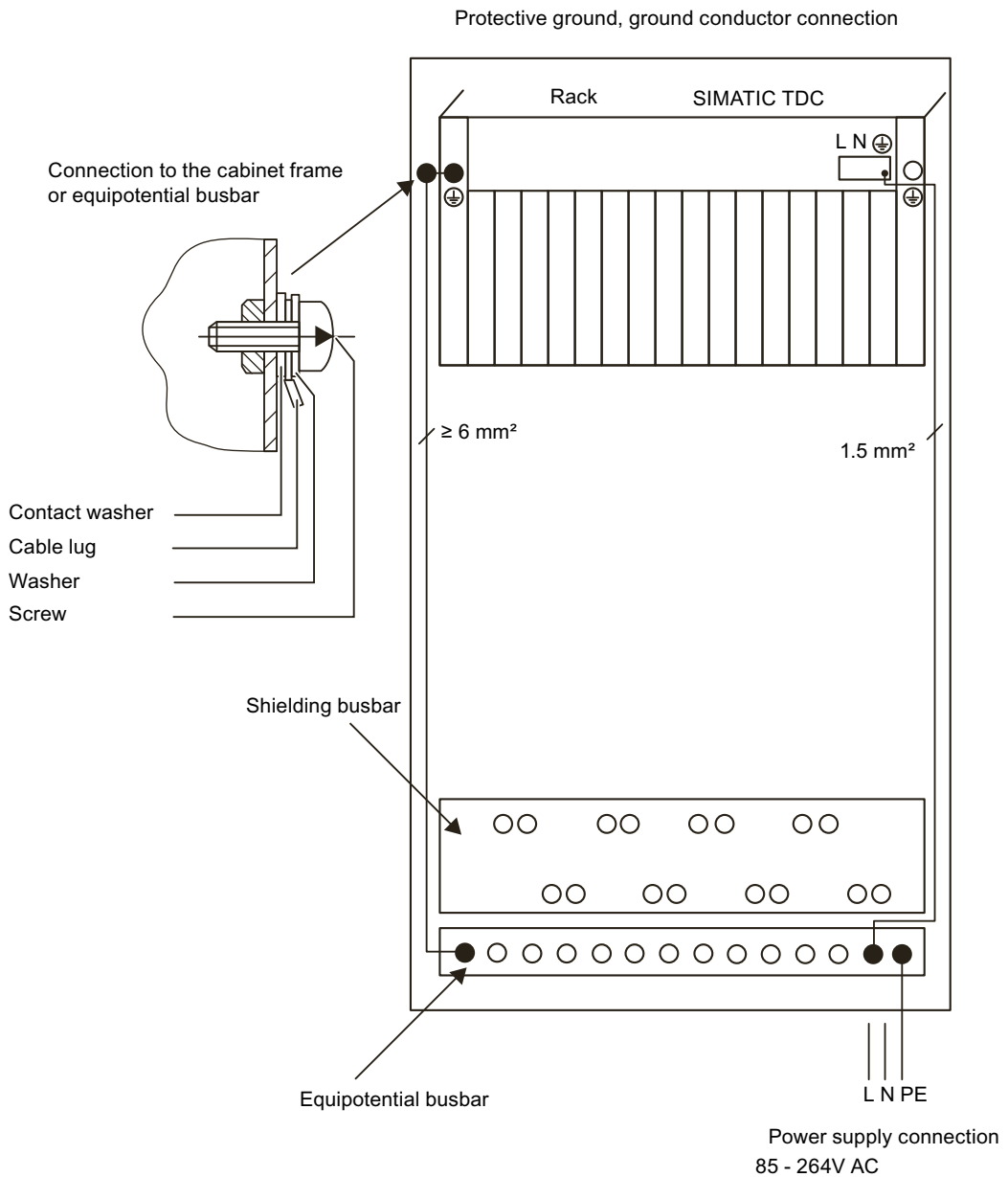

2.13 Power losses in the control cabinet

The dissipation capability of a cabinet and therefore the air intake temperature of the rack depends on the type of cabinet, on the ambient temperatures and on the internal arrangement of the devices.

Built-in versions

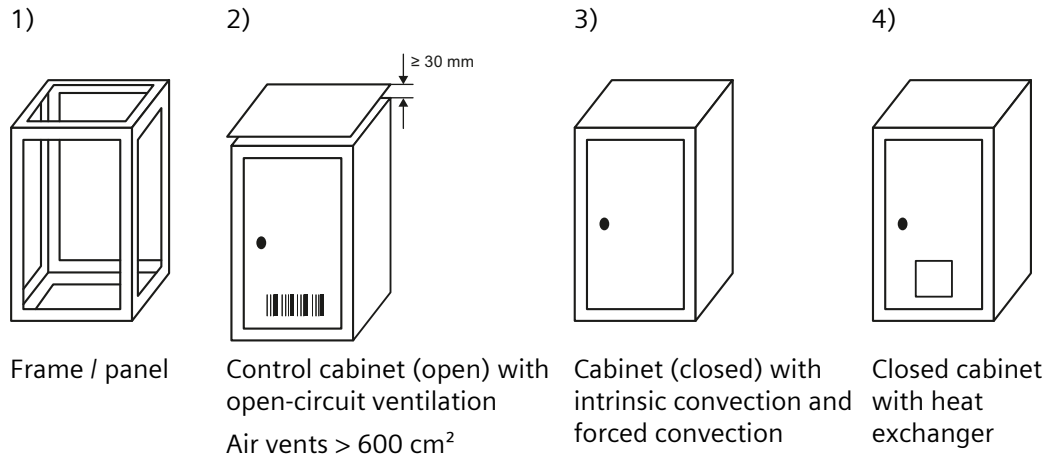

For installation variants 1) and 2), it is presumed that there is a clearance of at least 1 meter between the top of the control cabinet and the building's ceiling.

SHUTDOWN MODE

Using the SHUTDOWN MODE switch the user can select whether to shut down the rack immediately on failure of the first fan, or not until an additional fan failure.

Shutdown mode	
ONE / ON	Shutdown is initiated upon the failure of one fan
TWO / OFF	Shutdown is initiated upon the failure of one or more fans

For additional rack-specific information see:

UR6021 (6DD1682-0CH3) Control and display elements [\(Page 45\)](#)

UR5213 (6DD1682-0CH2) Control and display elements [\(Page 59\)](#)

UR5213 (6DD1682-0CH0) Control and display elements [\(Page 69\)](#)

NOTE

In the SHUTDOWN MODE, the internal output voltages of the rack are switched off. External voltages connected to the module input must be switched off simultaneously (refer to section Machinery directive [\(Page 21\)](#)).

Air intake temperature

The maximum air intake temperature on the SIMATIC TDC may not be exceeded. The following limits are valid, depending on the "shutdown mode" switch setting.

Shutdown mode	Maximum air intake temperature up to 2000 m above sea level
ONE / ON Shutdown on fan failure	60° Centigrade
TWO / OFF Shutdown on failure of two fans	35° Centigrade

2.14 Power supply

Measures against disturbance voltages

The following notes related to the EMI/EMC measures to take for systems/plants should be observed in order to avoid disturbance peaks on the supply cables in the cabinet:

Interference suppression on mains

The power supply of the rack already has a line filter with sufficient attenuation (refer to "Manufacturers declaration").

For more demanding applications, you can install an additional line filter (e.g. 250 V AC / 10 A) or overvoltage arrester in the mains line, as close as possible to the cable entry on the cabinet. Ground of the line filter/arrester must be wired to the equipotential busbar of the cabinet using the shortest possible conductor length.

24 V power supply

To attenuate external interference, a line filter must be provided for the 24 V power supply of the digital I/O (e.g. SIFI-B line filter, Order No. B84112-B-.... from Epcos/NF 1-1 line filter of Phoenix Contact). This filter should be installed as close as possible to the terminal block. The shield connections of the line filter must be bonded to ground across the shortest possible distance.

The 24 V power supply must also be equipped with lightning/overvoltage protection.

For more information, refer to the installation manual "SIMATIC Automation Systems S7-400, Hardware and Installation

(<http://support.automation.siemens.com/WW/view/de/1117849/0/en>)".

NOTICE
<p>Network devices</p> <p>Safe electrical isolation to IEC 61131-2 IEC 61131-2 (11.1.2.1.3) must be ensured for all power supply units operated on SIMATIC TDC devices and modules.</p>

Potentials of power supply

In SIMATIC TDC, the ground connections of all secondary voltages are grouped and bonded to the rack enclosure in order to improve the signal to interference ratio and to ensure proper grounding.

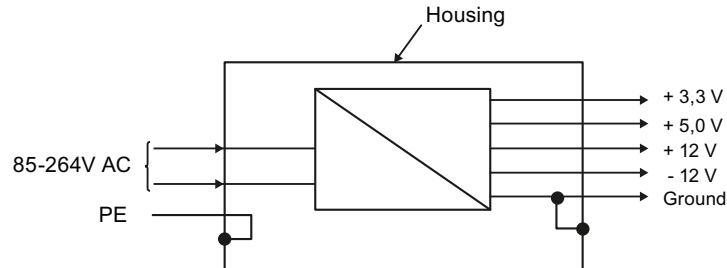

2.15 Rack

- The rack must be bonded to the grounding/equipotential busbar using the shortest possible conductor with a minimum cross-section of 16 mm²; refer to Equipotential bonding (Page 26).
- All modules and front panels must be screwed onto the rack. This rule also applies to commissioning phase!
- Unused slots must be provided with SIMATIC TDC dummy front panels type SR 51 6DD 1682-0DA1.
- The connectors must be screwed/interlocked to the front panel.
- The limit of the air intake temperature may not be exceeded on the rack; refer to Control cabinet (Page 24). The rack must be installed in a way that safely excludes heat accumulation; refer to Fire protection (Page 22).
- The air intake of the rack must be free of dust as far as possible. The air intake of the rack (bottom) must be cleaned at cyclic intervals depending on the degree of soiling.

NOTE

The modules may **not** be inserted or removed while the rack is on live voltage. Exception: Memory sub-modules MC 5xx / MMCs.

As a matter of principle it is not advisable to remove and insert memory sub-modules or front connectors on the live component.

For module-specific notes, refer to the corresponding user documentation (hardware).

2.16 Cables

- **All signal cables** you install must be shielded. All cables assembled by users must be wired with strain relief.
- **Serial signal lines** must be shielded. The shield must be bonded to a metalized connector housing, as well as to the shielding busbar. The cable shielding may not be wired to pin 1 of the connector.
- The **power cable** for the rack power supply does not require shielding. The permitted operating voltage of the power cable used may not be less than the supply voltage.
- **Power supply cables** for safety extra low voltages (e.g. 24 V DC) must be shielded. A power supply cable that is routed via interface module must be bonded to the shielding busbar as specified in section "Connection via interface module".
- **External power supply ground** must be bonded to the equipotential busbar; refer to "Equipotential bonding [\(Page 26\)](#)".
- **Cables on system side** and cables interconnecting the interface module with SIMATIC TDC should not be routed through the same cable duct.
- A minimum clearance of > 10 cm must be maintained **between signal lines and power cables** carrying voltages less than 500 V and > 30 cm to power cables carrying voltages of more than 1 kV.

Design and temperature resistance

All cables must be made of copper and be able to resist temperatures of up to at least 90 °C.

Connection via interface module

If interface modules are used, the shields of system-side cables and of routed the interface module to SIMATIC TDC must be bonded to ground directly above or below the interface module. Unshielded conductors that are terminated to screw terminals should be kept as short as possible.

All lines should be kept as short as possible.

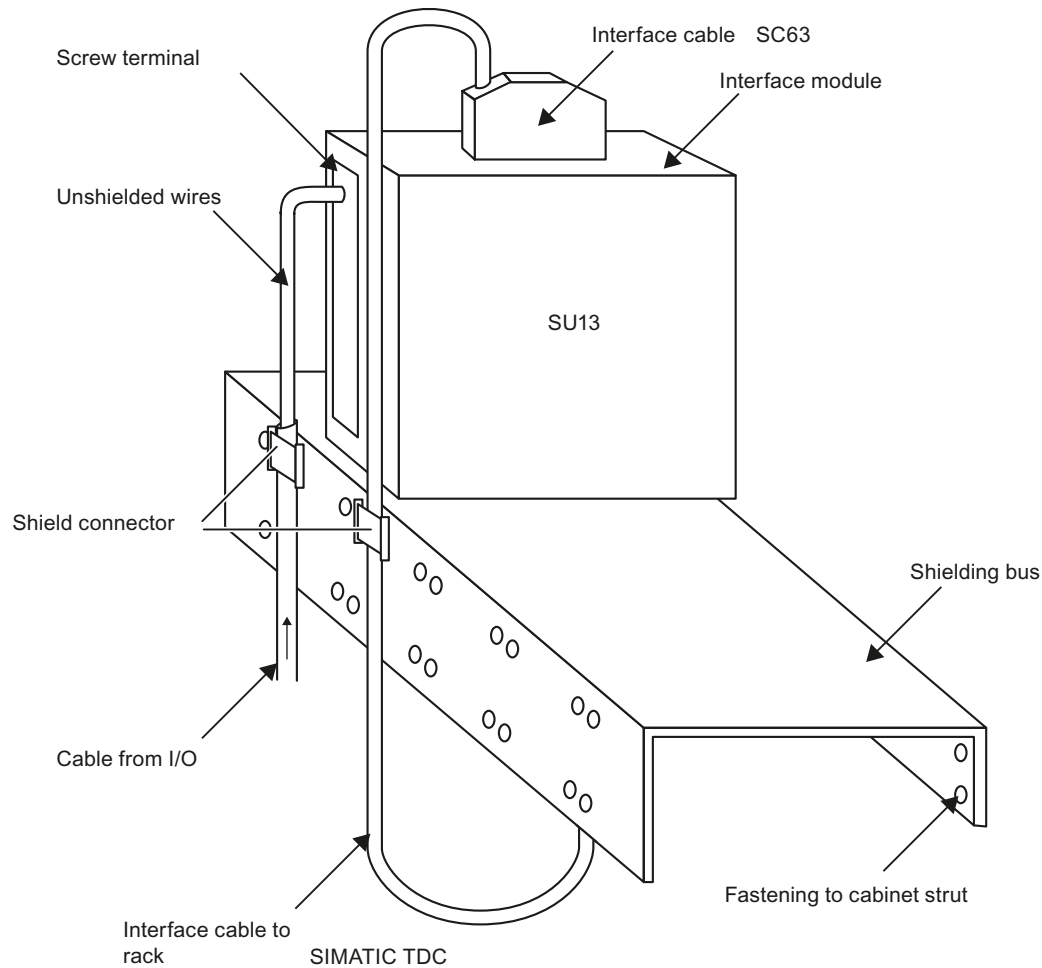

Connector X1 (UR6021 6DD1682-0CH3 and UR5213 6DD1682-0CH2)

The cable wired to connector X1 on the rack must be shielded. The shield should be terminated as close as possible to connector X1. You can connect conductor cross-sections from 0.5 mm² to 1.5 mm².

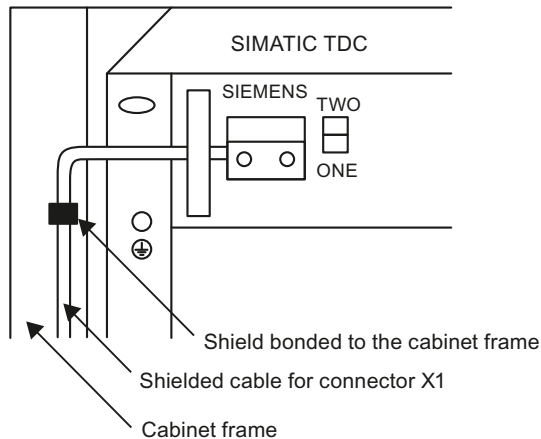

Comment: We recommend using ferrules when using flexible cables.

2.17 ESD Directives

Almost all of the SIMATIC TDC modules contain highly integrated components. Due to their technology, these components are highly sensitive to overvoltage and, therefore, to ESD.

ESD

The abbreviation stands for **e**lectrostatic **d**ischarge

Modules equipped with such components are identified by the following warning label on component side:



Electrostatic sensitive components can be destroyed by voltages and power levels far below human perception. Components or modules are possibly exposed to such voltages when touched by humans who have not been electrostatically discharged. Following such voltage peaks, it is usually impossible to identify malfunction of the component immediately, as it needs an extended operating time before such malfunctions are disclosed.

Handling ESD modules

- As a matter of principle, you should never touch electronic modules unless this is unavoidable in the course of work to be carried out on the component.
- Do not touch components unless
 - you are continuously grounded by means of an ESD bracelet, or
 - or by wearing ESD shoes, or ESD shoe grounding strips.
- Always discharge your body before you touch an electronic module. This can be done quite simply by touching a conductive, grounded object immediately before you handle the component (e.g. bright metal parts of the control cabinet, water pipe etc.)
- Modules may not come into contact with highly insulating materials that are subject to electrostatic charge, e.g. plastic foils, insulating table plates, clothing made of artificial fiber.
- Modules must always be placed onto conductive surfaces (table with ESD mat, conductive ESD foam rubber, ESD packaging bags, ESD transport containers, cardboard or paper mats).
- Modules may not be brought close to data terminals, monitors, or television sets.

Measuring and modifying ESD modules

- Measurements may only be taken on the modules when
 - The measuring device is grounded (e.g. via PE conductor), or
 - The measuring head has been briefly discharged (e.g. by touching a bright metal part of the control enclosure) prior to measurement with an electrically isolated measuring device.

Always use ESD soldering irons for soldering work on modules, or at least grounded soldering tips.

Shipping modules

Modules and components must always be stored and shipped in conductive packing materials (e. g. metalized plastic boxes, metal containers).

If using non-conductive packaging, you must protect the modules with a wrapping of made of conductive material, e.g. conductive foam rubber, or household aluminum foil.

The following figure once again emphasizes the necessary ESD protective measures.

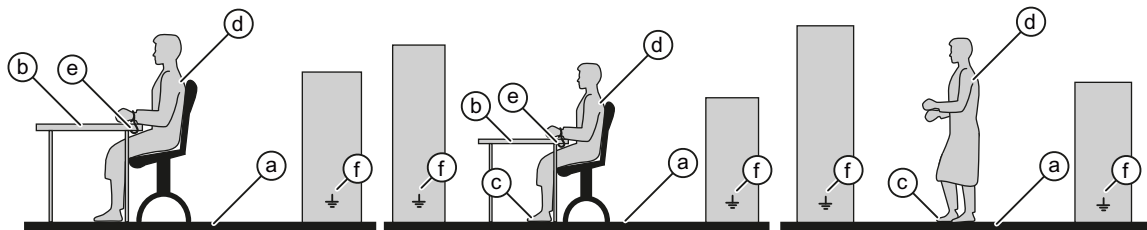

- a Conductive flooring
- d ESD coat
- b ESD tables = ESD chain
- c ESD shoes
- f Ground connection of the cabinets
- e ESD bracelet

General technical specifications

3.1 Climatic conditions

Table 3-1

Storage and transport conditions	IEC 60721 Part 3-2 Class 2K1, without condensation
Storage temperature	-40 °C to +70 °C
Operating conditions	IEC 60721 Part 3-3 Class 3K3, stationary use, weather-protected
Operating temperatures (air intake temperature)	0 °C to + 60 °C; shutdown mode ONE 0 °C to + 35 °C; shutdown mode TWO refer to "Power losses in the control cabinet (Page 33)"
Atmospheric pressure Storage Operation	1080 to 660 hPa (corresponds to -1000 m to +3500 m) 1080 to 795 hPa (corresponds to -1000 m to +2000 m)
Pollutant stress Gases posing the risk of malfunction Dust posing the risk of malfunction	ISA-71.04 severity level G3 SO ₂ 10 cm ³ /m ³ H ₂ S 1 cm ³ /m ³ Conditions of use according to IEC 60721, Part 3-3; Class 3S2 (without sand in air)

3.2 Electrical protection and safety requirements

Safety regulations	IEC 61131-2
Protection class	Protection class I (with PE/ground conductor)
Protection against the ingress of foreign particles and water	IP 20

3.3 External supply of the SIMATIC TDC modules (digital outputs)

Safety extra low voltage (SELV/PELV circuit) to IEC 60364-4-41.

3.4 Mechanical requirements

The following table provides information on the type and scope of checks regarding mechanical ambient conditions.

Tested for	Test standard	Note
Vibrations	Vibration test according to IEC 60068-2-6 (sine)	Type of vibration: Frequency cycles with a rate of change of 1 octave/minute 10 Hz ≤ f ≤ 58 Hz, constant amplitude 0.075 mm 58 Hz ≤ f ≤ 150 Hz, constant acceleration 1 g Duration of vibration: 10 frequency cycles per axis in each of the 3 axes which are perpendicular to each other
Shock	Shock test according to IEC 60068-2-27	Type of shock: half-sine Strength of shock: 10 g peak value, 16 ms duration Shock direction: 3 shocks each in +/- direction in each of the three perpendicular axes

3.5 Electromagnetic requirements (industry)

Interference emission	EN 61000-6-4 : 2007 + A1:2011
Immunity to interference	EN 61000-6-2 : 2005

NOTICE
<p>Using two-way radios and mobile telephones The use of two-way radios and mobile phones in the immediate range of SIMATIC TDC can influence the operation of the device.</p>

Rack

4.1 Rack UR6021 (6DD1682-0CH3)

4.1.1 Areas of application

Rack UR6021 with 21 slots forms the mechanical base for SIMATIC TDC

The system power supply is installed in the rear area of rack.

There is a fan tray in the upper part of the rack, which includes the monitoring and signaling functions in addition to the fans.

The fan tray can be ordered as spare part (6DD1683-0CH3) and can be replaced by qualified personnel.

A high-performance 64-bit backplane bus supports high-speed data exchange between the inserted modules.

The CPU555 used in UR6021 supports P0 functionality.

For fast, direct communication between CPU555 modules, the rack UR6021 has a P0 connector in slots 01, 02, 03, 04, 09, 11, 13 and 15. Each CPU555 can communicate with up to 7 additional CPU555 by means of the PCIe interface via the backplane bus (P0 connector). This means that a point-to-point connection always exists between any two CPU555 modules.

See also

[Ventilation/cooling \(Page 52\)](#)

4.1.2 Mechanical layout

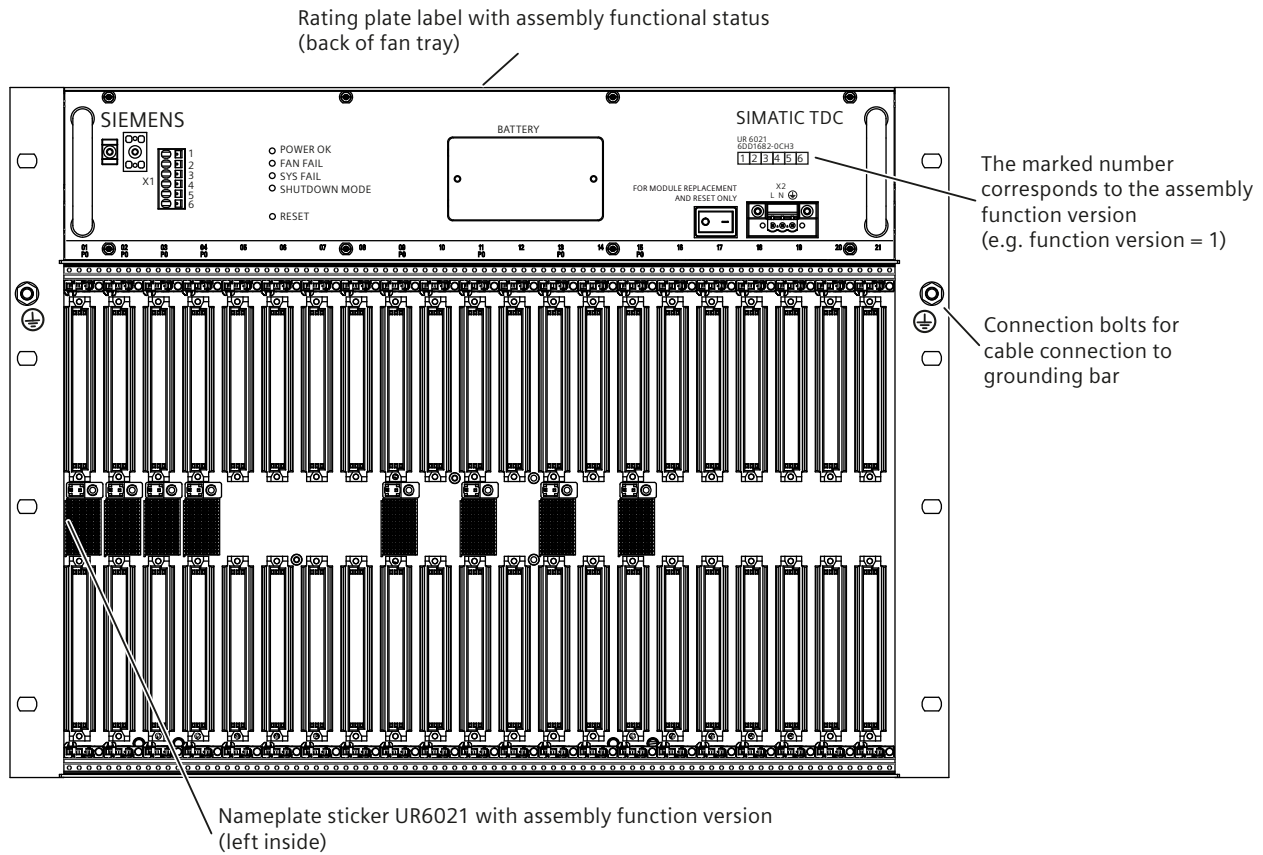

Figure 4-1 Rack UR6021 (front view)

Fan tray (6DD1683-0CH3)

The fan tray is inserted and screwed into the upper part of the rack. The fan tray contains six fans and the control and monitoring functions for the rack.

4.1.3 Control and display elements

X1

3 signaling relays, 230 V AC floating potential (3 x 2 contacts)

NOTE

Mixed assignment

Contacts consisting of combinations of safety extra-low voltage and hazardous voltages are not permitted.

SHUTDOWN MODE

A system shutdown mode can be set in accordance with the switch position S1.1 (in the battery compartment) as response to the failure of one or two fans.

- OFF = Shutdown on failure of two fans (SHUTDOWN MODE LED = on)
- ON = Shutdown on failure of one fan (SHUTDOWN MODE LED = flashes)

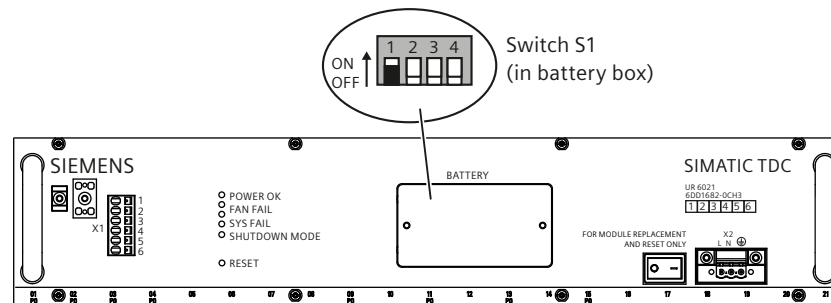

Figure 4-2 Front view of the fan tray

LED

The four LEDs signal the operating state of the rack.

RESET

You can restart all modules by pressing the submerged pushbutton (rack RESET).

BATTERY

Backup battery compartment (1 x AA lithium battery)

X2

Line voltage connection

4.1.4 Status and fault displays

Table 4-1 Status displays for UR6021

LED	Display	Rack state
POWER OK (green or red)	green is on	fault-free operation
	red is on	fault (refer to voltage monitoring)
FAN FAIL (red)	Off	fault-free operation
	On	fault (at least one fan has failed)
SYSFAIL (red)	Off	fault-free operation
	On	System was stopped
SHUTDOWN MODE (yellow)	On	Shutdown on failure of two fans (corresponds to the OFF position of switch S1.1)
	Flashes	Shutdown on failure of one fan (corresponds to the ON position of switch S1.1)

4.1.5 Power supply

Mains connection

Mains is connected to the 3-pin screw terminal block on the right side of the power supply unit.

NOTE

Always use the integrated strain relief for the mains cable on the 3-pin screw terminal block.

The pin assignment is printed onto the front panel.

Input voltage	120/230 V AC 110/220 V DC
Test voltage Primary ↔ PE	1500 V AC
Power consumption	800 W (apparent power approx. 835 VA)
Cable cross-section	3 x 1.5 mm ² (copper stranded wires dressed with wire end ferrules with insulating collars; stripped length: 10-12 mm according to the used wire end ferrule)
Input current	$I_n = 9 \text{ A}$ $I_s < 40 \text{ A}$ (inrush peak)
External fuse (dimensioning)	The power supply is equipped with an internal 20 A fuse. This means that only the mains supply has to be fused. It is recommended to use a standard 16 A thermo magnetic circuit-breaker (B characteristic). Alternatively, a slow-acting fuse may be used.

NOTE

A mains disconnect unit must be provided during installation of the rack.

NOTE

Use the switch only for replacing assemblies or restarting the rack. For maintenance work on the system, switch off the rack completely using the upstream disconnecter unit.

4.1.6 Wiring diagram

X2	Pin	Function
Screw terminal with screw lock (3x1.5 mm ² , stranded wires dressed with wire end ferrules with insulating collars) Make sure that the strain relief is properly mounted.	L	Line conductor
	N	Neutral conductor
		PE/ground conductor

X1	Pin	Function
Cage clamp terminal (0.5 mm ² –1.5 mm ² , stripped length 7 mm, stranded wires dressed with wire end ferrules with insulating collars) Make sure that the strain relief is properly mounted.	1, 2	SYSFAIL signaling contact
		NC contact
	3, 4	POWER signaling contact
		NO contact
	5, 6	FAN FAIL signaling contact
		NO contact

WARNING

PE terminal

The PE/ground conductor must be connected to the power supply.

The PE/ground terminal on the rack (min. 6 mm²) is inappropriate.

The PE/ground conductor must be green with yellow stripe (green/yellow).

Ungrounded installation of the rack is not planned.

4.1.7 Voltage monitoring

Input voltage

The input voltage is monitored for low level.

Input voltage	Reaction
Undervoltage < approx. 85 V	ACFAIL signal and CPU STOP, shutdown of output voltages <85 V

Voltage dips ≤ 20 ms are buffered.

The power supply unit and therefore the system are restarted automatically on recovery from a voltage dip below the permissible mains voltage.

Output voltage

All output voltages are monitored (e.g. for overload/short-circuit).

Voltage monitoring functions at the power supply outlet	Reaction
+5 V in the range from 4.75 V to 5.35 V	"POWER OK" LED is lit green;
+ 3.3 V in the range from +3.18 V to +3.5 V + 12 V in the range from +11 V to +13 V - 12 V in the range from -11 V to -13 V	

In all other cases, the "POWER OK" LED is lit red.

System failure alarm

Select the "Object properties" in the "STOP" tab of **HW Config** to configure the response of the relevant module to a system failure alarm (bus signal ***SYSFAIL=low**):

- The other modules also change to STOP
- The other modules remain in RUN

4.1.8 Battery backup

Battery connection

A backup battery must be installed in the battery box to enable the backup of configured values on power failure (using SAV function blocks).

Technical specifications of the battery

Backup battery	
Article number	6ES7971-0BA00
Type	1 x Lithium AA
Rated voltage	3.6 V
Rated capacity	2.3 Ah

You may only use batteries that have been approved by Siemens!



WARNING

Handling lithium batteries

Risk of injury, damage to assets, and emission of pollutants. Improper handling of a Lithium battery may cause its explosion and incorrect disposal of used lithium batteries may lead to emission of pollutants. For these reasons, you should strictly observe the following notes:

- Do not throw new or waste batteries into an open fire, or perform any soldering work on the cell body (max. temperature 100° C)
- Do not recharge waste batteries - risk of explosion!
- Do not open the battery.
- Always replace battery with one of the same type. Always order replacements from Siemens.
This ensures that you are in possession of a short circuit-proof type.
- You should return waste batteries to the battery manufacturer, dispose of the batteries as special waste at a recycling facility.

Backup time

Sample calculation:

Capacity of the backup battery: 2.3 Ah, 63 % is assumed for calculation.

Backup current: 200 µA (monitoring 20 µA + max. 180 µA for the slots, CPU555/CPU551 needs 3 µA)

Backup time = 2.3 Ah * 0.63 / 200 µA = 7245 h ≈ 300 days

This time is valid for a rack that is switched off. Only the battery monitoring function draws a current of 20 µA while the rack is powered on.

It is recommended to replace the batteries at annual intervals. The backup function is deactivated when the fan tray is removed.

Battery voltage monitoring

The CPU module inserted in slot 1 detects missing or low backup batteries and signals these states with a flashing "b".

Battery replacement

UnscREW and remove the lid of the battery compartment to remove the battery.

Observe correct polarity when inserting the battery. You should also take care not to bend the connection tabs of the battery holder during replacement.

To prevent data loss, you should always replace the battery while the rack is powered on.

See also

[Ventilation/cooling \(Page 52\)](#)

4.1.9 Modules

Make sure that the modules you insert are properly aligned in their relevant slot.

NOTICE

Damaging of the ESD braid

Do not push the modules towards the left when inserting these, because you would risk damage to the ESD braid of the modules already inserted. Observe this particularly at slot 1, as a metal spring has been installed in this slot.

If the ESD braid or a metal spring is severely damaged, the module can no longer be used because there is a risk of a short circuit with the potentials of a neighboring module.

NOTE

TSAVE area

To safeguard the integrity of the TSAVE area, you should delete the TSAVE area after connecting and disconnecting modules.

4.1.10 Power supply potentials

In SIMATIC TDC, the ground connections of all secondary voltages are grouped and bonded to the rack enclosure in order to improve the signal to interference ratio and to ensure proper grounding.

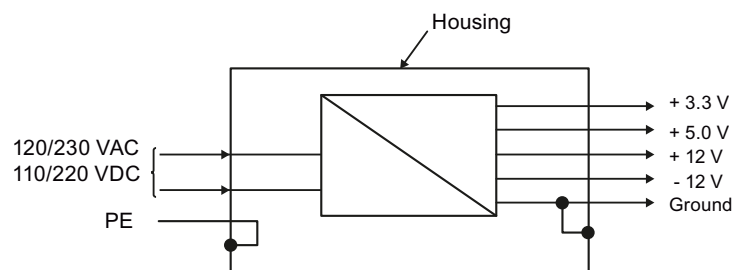

4.1.11 Ventilation/cooling

The rack is equipped with a fan tray with 6 fans for forced convection of the modules and the system power supply.

Since the rack is not equipped with an air filter, you should provide a filter on the cabinet if necessary.

NOTE

For more information, refer to section "Control cabinet (Page 24)".

NOTE

FANOPH

Using the FANOPH function block, you can read out the operating hours counter of the fan from the first CPU555 and monitor it for a limit.

Fan monitor

The fans are monitored (speed). Activation of the monitoring function is delayed in order to enable the reliable startup of the rack after you switched on power.

On failure of one or two fans, the power supply is shut down depending on the operating mode in order to prevent thermal destruction of the modules.

The operating mode (SHUTDOWN MODE) is selected using switch S1.1, which is integrated in the power supply. The power supply is shut down if one fan has failed and switch position "ON" is set, or if two fans have failed and switch position "OFF" is set.

NOTICE

Safe isolation from supply

Switch off power to the rack before you remove the screws of the battery compartment.

The battery compartment cover must be unscrewed to actuate switch S1.

NOTICE

ESD Directives

Observe the corresponding ESD directives.

The operating mode setting is indicated by the "SHUTDOWN MODE" LED on the front panel.

See section "Status and fault displays (Page 46)".

NOTICE
<p>Forced cooling</p> <p>If the modules require forced cooling (e.g. CPU555), always set the "SHUTDOWN MODE" slide switch S1.1 to "ON" for air intake temperatures from 0 °C to 60 °C.</p> <p>You may only set the position of switch S1.1 to "OFF" if it can be ensured that the air intake temperature at the rack does not exceed 50 °C.</p> <p>The power supply is not shut down on failure of a single fan, but the corresponding backplane bus signal (FANAL*) is activated and can be detected by the configuration software.</p>

Replacing the fan tray

The fan tray is can be ordered as a replacement part and be replaced.

Fan try	
Article number	6DD1683-0CH3



Electrostatic sensitive components can be destroyed by voltages and power levels far below human perception. Components or modules are possibly exposed to such voltages when touched by humans who have not been not electrostatically discharged. Following such voltage peaks, it is usually impossible to identify malfunction of the component immediately, as it needs an extended operating time before such malfunctions are disclosed.

NOTICE
<p>Replacing the fan tray</p> <p>If the fan tray is damaged, it may not be installed.</p>

Proceed as follows to replace the fan tray:

1. Make sure that the leads to X2 and possibly X1 are de-energized and secure them against reconnection.
2. Ensure that adjacent live parts cannot be touched.
3. Remove the power connector X2.
4. If necessary, remove the wires to X1 (including the strain relief and shield connection).
5. Loosen the 8 screws on the top and bottom of the fan tray.
6. Pull the fan tray out of the rack by the handles.

⚠ CAUTION
<p>Sharp-edged front panel</p> <p>The edges and corners of the front plate of the fan tray may cause injury. Use suitable protective gloves to remove and install it.</p>

7. Slide the new fan tray into the rack until it clicks and the faceplate is flush to the front panel.
8. Fasten the fan tray (8 screws on the top and bottom of the fan tray).
9. Insert a new backup battery; see section "Battery backup (Page 50)".
10. If necessary, connect the wires to X1 (including the strain relief and shield connection).
11. Connect the power connector X2.
12. Switch on the power again.

Signaling relay

Three 230 V signaling relays with floating potential facilitate external evaluation of the rack system states.

NOTICE

Assignment of the contacts

Contacts consisting of combinations of safety extra-low voltage and hazardous voltages are not permitted.

Signaling relay	Terminal X1	Contact in switched off state	Contact in error-free operation	LED in error-free operation
SYSFAIL	1.2	Closed	Closed	Off
POWER	3.4	Open	Closed	green is on
FAN FAIL	5.6	Open	Closed	Off

4.1.12 Technical specifications

Article number

Rack UR6021	6DD1682-0CH3
-------------	--------------

General data

Safety	EN 61131-2
Degree of protection	IP 20
Protection class	Protection class 1 with PE/ground conductor

Storage temperatures	-40 °C to +70 °C
Operating temperatures	0 °C to +60 °C
Relative air humidity	5 % to 95 %, no condensation
Atmospheric pressure	Operation: 1080 hPa to 795 hPa Storage: 1080 hPa to 660 hPa

Power input

Rated input voltage	
<ul style="list-style-type: none"> • Rated value • Permissible range 	<ul style="list-style-type: none"> • 120 V AC to 230 V AC 110 V DC to 220 V DC • 85 V AC to 264 V AC (wide-range input) 93.5 V DC to 253 V DC
Rated input current	
<ul style="list-style-type: none"> • At 120 V AC • At 230 V AC • At 110 V DC • At 220 V DC 	<ul style="list-style-type: none"> • 6.7 A • 3.5 A • 7.3 A • 3.7 A
Max. inrush current	< 40 A
Line frequency	
<ul style="list-style-type: none"> • Rated value (AC) (DC) • Permissible range 	<ul style="list-style-type: none"> • 50/60 Hz (0 Hz) • 47-63 Hz
Power factor	EN 61000-3-2
Pollution degree	2
Overvoltage category	II
Power failure backup	min. 20 ms

Output voltages of the power supply

Rated output voltage	Output current	
	Total	for the modules
+5 V	120 A	79 A
+3.3 V	60 A	36 A
+12 V	17 A	5 A
-12 V	17 A	5 A

NOTE

Make sure that you do not exceed a total of 600 W (continuous load at 60 °C). This must be ensured in your configuration.

The output currents of the individual modules are listed in the respective description.

All outputs are sustained short circuit-proof and **do not** need a basic load.

Battery

Current load	Approx. 20 µA for the monitoring and max. 180 µA for the slots 1-21
--------------	---

Relay contacts (X1)

Rated voltage (AC)	230 V (max. 264 V)
Rated current	2 A

NOTICE

Assignment of the contacts

Contacts consisting of combinations of safety extra-low voltage and hazardous voltages are not permitted.

Dimensions

Number of rack slots	21
Dimensions W x H x D [mm]	approx. 482.6 x 354.9 x 343
Weight	22 kg

Dimensional drawing

Dimensions in mm

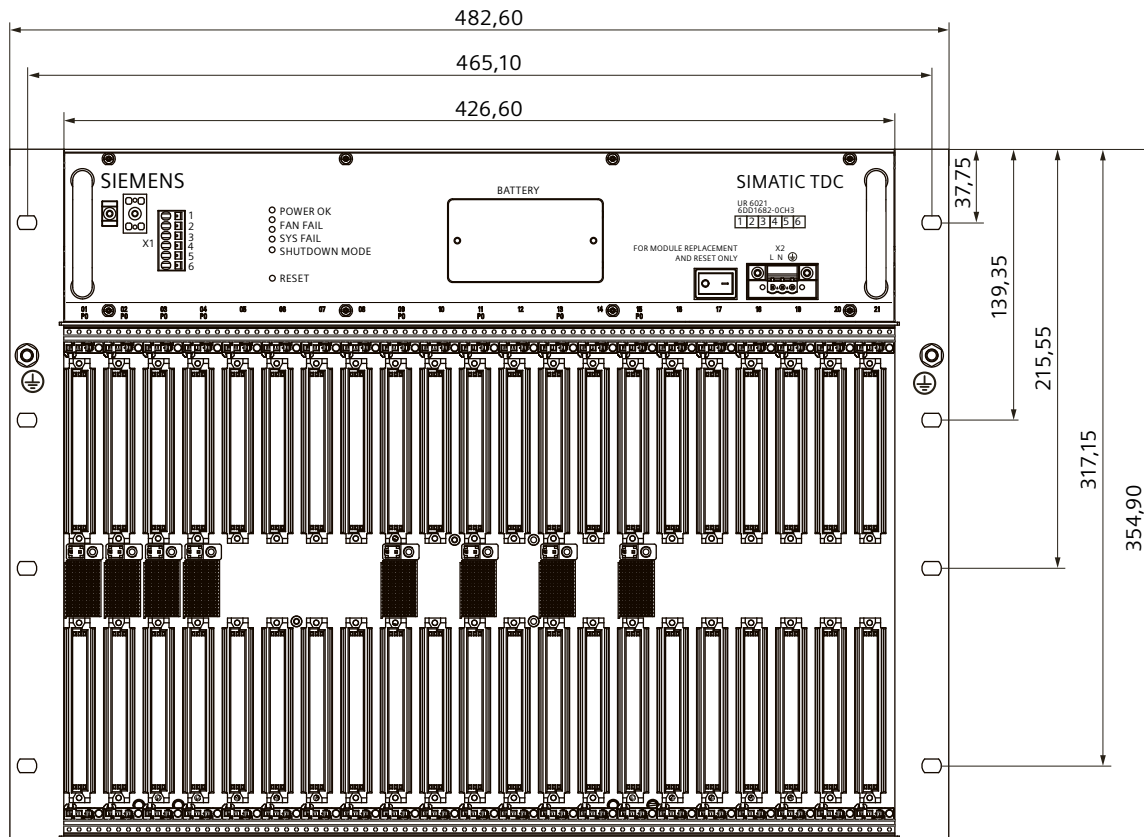

Figure 4-3 Dimension drawing of rack UR6021

4.2 Rack UR5213 (6DD1682-0CH2)

4.2.1 Areas of application

Rack UR5213 with 21 slots forms the mechanical base for SIMATIC TDC and features an integrated system power supply and integrated system fans. A high-performance 64-bit backplane bus supports high-speed data exchange between the inserted modules.

4.2.2 Mechanical layout

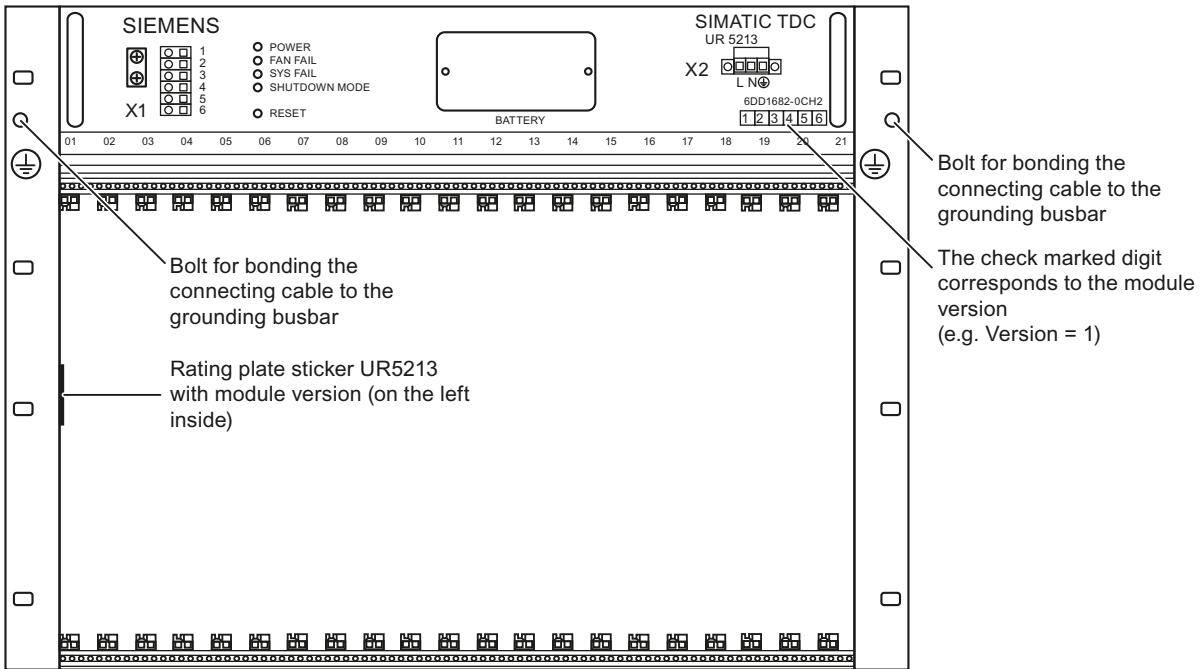

Figure 4-4 Rack UR5213 (front view)

Power supply

The power supply with integrated fan for forced convection is installed in the rear section of the rack.

4.2.3 Control and display elements

X1

3 signaling relays, 230 V floating potential (3 x 2 contacts)

SHUTDOWN MODE

A system shutdown mode can be set in accordance with the switch position S1.4 (in the battery box) as response to the failure of one or two fans.

The operating mode setting is indicated by the "SHUTDOWN MODE" LED on the front panel.

- OFF = Shutdown on failure of two fans (SHUTDOWN MODE LED = off)
- ON = Shutdown on failure of one fan (SHUTDOWN MODE LED = on)

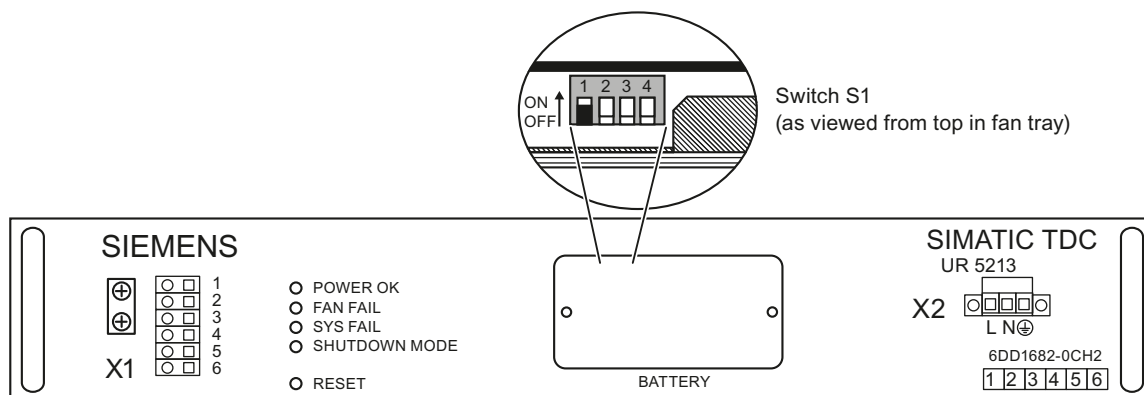

Figure 4-5 Front view of the fan tray

LED

The four LEDs signal the operating state of the rack.

RESET

You can restart all modules by pressing the submerged pushbutton (rack RESET).

BATTERY

Backup battery compartment (1 x AA lithium battery)

X2

Line voltage connection

4.2.4 Status and fault displays

Table 4-2 Status displays for UR5213

LED	Display	Rack state
POWER (green or red)	green is on	fault-free operation
	red is on	fault (refer to voltage monitoring)
FAN FAIL (red)	Off	fault-free operation
	On	fault (at least one fan has failed)
SYSFAIL (red)	Off	fault-free operation
	On	System was stopped
SHUTDOWN Mode (yellow)	On	Shutdown on failure of two fans (corresponds to the OFF position of switch S1.4)
	Flashing	Shutdown on failure of one fan (corresponds to the ON position of switch S1.4)

4.2.5 Power supply

Mains connection

Mains is connected to the 3-pin screw terminal block on the right side of the power supply unit.

NOTE

Always use the integrated strain relief for the mains cable on the 3-pin screw terminal block.

The pin assignment is printed onto the front panel.

Input voltage	85–264 V AC
Test voltage Primary ↔ PE	1350 V AC
Power consumption	800 W (apparent power approx. 835 VA)
Conductor cross-section	3x1.5 mm ² (stranded wires dressed with wire end ferrules with ISO insulating collars)
External fuse (dimensioning)	In = 9 A Is = <40 A (inrush peak) The power supply is equipped with an internal 20 A fuse. This means that only the mains supply has to be fused. It is recommended to use a standard 16 A thermo magnetic circuit-breaker (B characteristic). Alternatively, a slow-acting fuse may be used.

NOTE

A mains disconnect unit must be provided during installation of the rack.

4.2.6 Wiring diagram

X2	Pin	Function
Screw terminal with screw lock (3*1.5 mm ² , stranded wires dressed with wire end ferrules with insulating collars) Make sure that the strain relief is properly mounted.	L	Line conductor
	N	Neutral conductor
		PE/ground conductor

X1	Pin	Function
Cage clamp terminal (0.5 mm ² –1.5 mm ² , stranded wires dressed with wire end ferrules with insulating collars) Make sure that the strain relief is properly mounted.	1, 2	SYSFAIL signaling contact
		NC contact
	3, 4	POWER signaling contact
		NO contact
	5, 6	FAN FAIL signaling contact
		NO contact

 WARNING
The PE/ground conductor must be connected to the power supply. A PE/ground terminal on the rack is inappropriate. The PE/ground conductor must be green with yellow stripe (green/yellow).

Ungrounded installation of the rack is not planned.

4.2.7 Voltage monitoring

Input voltage

The input voltage is monitored for low level.

Input voltage	Reaction
Undervoltage < approx. 85 V	ACFAIL signal and CPU STOP, shutdown of output voltages <85V

Voltage dips ≤ 20 ms are buffered.

The power supply unit and therefore the system are restarted automatically on recovery from a voltage dip below the permissible mains voltage.

The power on/off sequence (e.g. generation of a RESET or SYSFAIL signal) corresponds to the reaction to manual operation of the mains switch.

Output voltage

All output voltages are monitored (e.g. for overload/short-circuit).

Voltage monitoring functions at the power supply outlet	Reaction
+5 V in the range from 4.75 V to 5.35 V	"POWER OK" LED is lit green;
+ 3.3 V in the range from +3.18 V... +3.5 V + 12 V in the range from +11 V to +13 V - 12 V in the range from -11 V to -13 V	

In all other cases, the "POWER OK" LED is lit red.

System failure alarm

Select the "Object properties" in the "STOP" tab of **HWConfig** to configure the response of the relevant module to a system failure alarm (bus signal ***SYSFAIL=low**):

- Modules can reset their digital and analog outputs
- CPU modules can go into the "STOP" state ("H" is displayed permanently)

4.2.8 Battery backup

Battery connection

A backup battery must be installed in the power supply circuit to enable the backup of configured values on power failure (using SAV function blocks).

Technical specifications of the battery

Backup battery	
Article number	6ES7971-0BA00
Type	1 x Lithium AA
Rated voltage	3.6 V
Rated capacity	2.3 Ah

You may only use batteries that have been approved by Siemens!

 WARNING
<p>Handling lithium batteries</p> <p>Risk of injury, damage to assets, and emission of pollutants. Improper handling of a Lithium battery may cause its explosion and incorrect disposal of used lithium batteries may lead to emission of pollutants. For these reasons, you should strictly observe the following notes:</p> <ul style="list-style-type: none"> • Do not throw new or waste batteries into an open fire, or perform any soldering work on the cell body (max. temperature 100° C), or recharge the battery - risk of explosion! Do not open the battery and always replace it with one of the same type. Always order replacements from Siemens. This ensures that you are in possession of a short circuit-proof type. • You should return waste batteries to the battery manufacturer, dispose of the batteries as special waste at a recycling facility.

Backup time

Sample calculation:

Capacity of the backup battery: 2.3 Ah, 63 % is assumed for calculation

Backup current: 200 μ A (monitoring 20 μ A + max. 180 μ A for the slots, a CPU 551 needs 2.2 μ A)

Backup time = $2.3 \text{ Ah} * 0.63 / 200 \mu\text{A} = 7245 \text{ h} \approx 300 \text{ days}$

This time is valid for a rack that is switched off. Only the battery monitoring function draws a current of 20 μ A while the rack is powered on.

It is recommended to replace the batteries at annual intervals. The backup function is deactivated while the fan tray is removed.

Battery voltage monitoring

The CPU module inserted in slot 1 detects missing or low backup batteries and signals these states with a flashing "b".

Battery replacement

UnscREW and remove the lid of the battery compartment to remove the battery. Observe correct polarity when inserting the battery. You should also take care not to bend the connection tabs of the battery holder during replacement.

You should always replace the battery while the rack is powered on in order to prevent data loss.

4.2.9 Modules

Make sure that the modules you insert are properly aligned in their relevant slot.

NOTICE

Damaging of the ESD braid

Do not push the modules towards the left when inserting these, because you would risk damage to the ESD braid of the modules already inserted. Observe this particularly at slot 1, as a metal spring has been installed in this slot.

If the ESD braid or a metal spring is severely damaged, the module can no longer be used because there is a risk of a short circuit with the potentials of a neighboring module.

NOTE

TSAVE area

To safeguard the integrity of the TSAVE area, you should delete the TSAVE area after connecting and disconnecting modules.

4.2.10 Power supply potentials

In SIMATIC TDC, the ground connections of all secondary voltages are grouped and bonded to the rack enclosure in order to improve the signal to interference ratio and to ensure proper grounding.

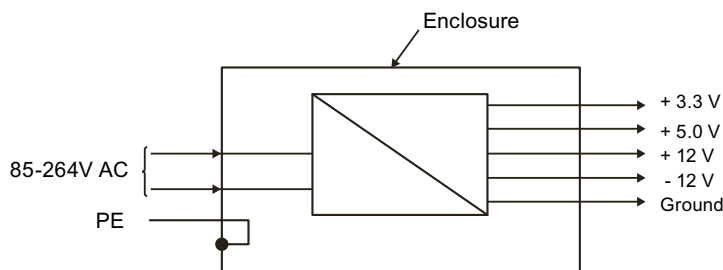

4.2.11 Ventilation/cooling

The rack is equipped with three fans for forced convection of the modules and with one fan for the system power supply.

Since the rack is not equipped with an air filter, you should provide a filter on the cabinet if necessary.

NOTE

For more information, refer to section "Equipotential bonding (Page 26)".

Fan monitoring

The fans are monitored (speed). Activation of the monitoring function is delayed in order to enable the reliable startup of the rack after you switched on power.

On failure of one or two fans, the power supply is shut down depending on the operating mode in order to prevent thermal destruction of the modules.

Select the operating mode (SHUTDOWN MODE) using switch S1.4 that is integrated in the power supply. The power supply is shut down if one fan has failed and switch position "ON" is set, or if two fans have failed and switch position "OFF" is set.

To set switch S1, unscrew the front panel and slightly pull it forward until you can reach the switch through the gap. Switch off power to the rack before you open the panel.

 WARNING
--

Switch off power to the rack before you remove the front panel screws.
--

 CAUTION
--

Observe the corresponding ESD Directives.

The operating mode setting is indicated by the "SHUTDOWN MODE" LED on the front panel. Refer to chapter "Status and fault displays".

 WARNING
--

Always set the "Shutdown mode" dip switch S1.4 to "ON" for modules requiring forced convection (e.g. CPU551) at air intake temperatures from 0 °C to 60 °C.

You may only set the position of switch S1.4 to "OFF" if it can be assured that the air intake temperature at the rack does not exceed 35 °C.

The power supply is not shut down on failure of a single fan, but the corresponding backplane bus signal (FANAL*) is activated and can be detected by the configuration software.

Signaling relay

Three 230 V signaling relays with floating potential facilitate external evaluation of the rack's system states.

Table 4-3 Signaling relay

Signaling relay	Terminal X1	Contact in switched off state:	Contact in error-free operation	LED in error-free operation
SYSFAIL	1,2	Closed	Closed	Off
POWER	3,4	Open	Closed	green is on
FAN FAIL	5,6	Open	Closed	Off

4.2.12 Technical specifications

Article number

Rack UR5213	6DD1682-0CH2
-------------	--------------

General data

Safety	EN 61131-2
Degree of protection	IP 20
Protection class	Protection class 1 with PE/ground conductor

Storage temperatures	-40 °C to +70 °C
Operating temperatures	0 °C to +60 °C
Relative air humidity	5 % to 95 %, no condensation
Atmospheric pressure	Operation: 1080 hPa to 795 hPa Storage: 1080 hPa to 660 hPa

Power input

Input voltage • Rated value • Permissible range	120/230 V AC 220 V DC 85 V AC to 264 V AC 198 V DC to 253 V DC (extended range input)
Rated input current • At 120 V AC • At 230 V AC • At 220 V DC	4.45 A 2.3 A 2.38 A
Max. inrush current	< 40 A

Line frequency	50/60 Hz
<ul style="list-style-type: none"> • Rated value • Permissible range 	47-63 Hz
Power factor	EN 61000-3-2
Overvoltage category	II
Pollution degree	2
Power failure backup	min. 20 ms

Output voltages

The following lists the maximum current load on the output voltages of the rack.

Rated output voltage	Max. output current load on the module type
+5 V	36 A
+3.3 V	44 A
+12 V	4.6 A
-12 V	4 A

Total output power may not exceed 320 W. This must be ensured in your configuration.

The output currents are listed in the respective description.

The output power limit of 320 W is not exceeded even in a full assembly of the rack consisting of the module types CPU551, SM500, CP51M1, CP50M1 and CP52A0.

NOTE

If using other modules, you must check the individual maximum currents and verify the maximum load of 320 W.

All outputs are sustained short circuit-proof and **do not** need a basic load.

Battery

Current load	Approx. 20 μ A for the monitoring function and max. 180 μ A for slots 1-21
--------------	--

Relay contacts

Rated voltage (AC)	230 V (max. 264 V)
Rated current	2 A

Dimensions

Number of rack slots	21
Dimensions W x H x D [mm]	approx. 482.6 x 354.9 x 343
Weight	Approx. 20 kg

Dimensional drawing

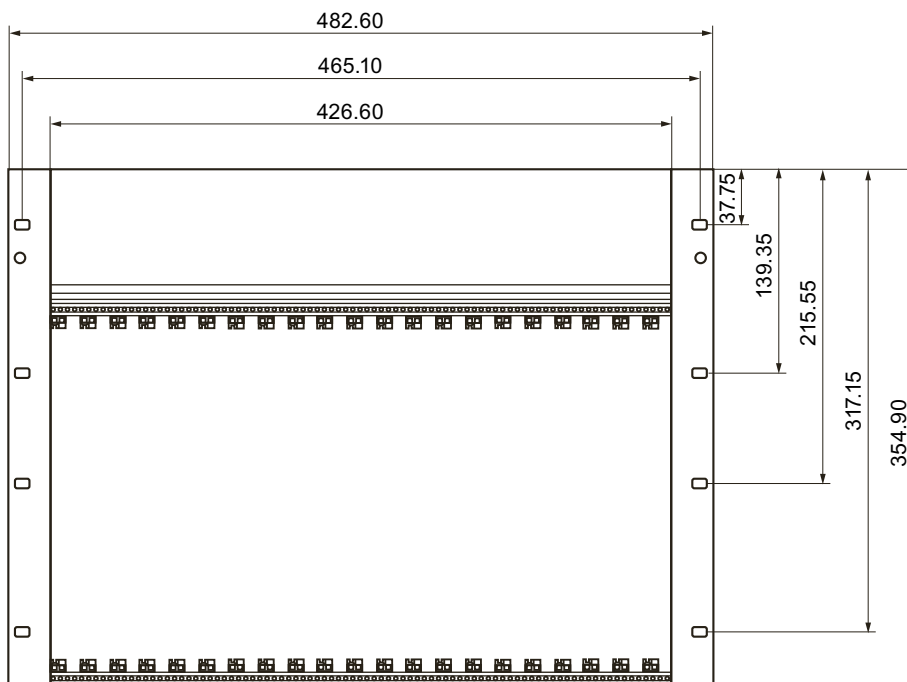

Figure 4-6 Dimensional drawing of rack UR5213

4.3 Rack UR5213 (6DD1682-0CH0)

4.3.1 Areas of application

Rack UR5213 with 21 slots forms the mechanical base for SIMATIC TDC and features an integrated system power supply and integrated system fans. A high-performance 64-bit backplane bus supports high-speed data exchange between the inserted modules.

4.3.2 Mechanical layout

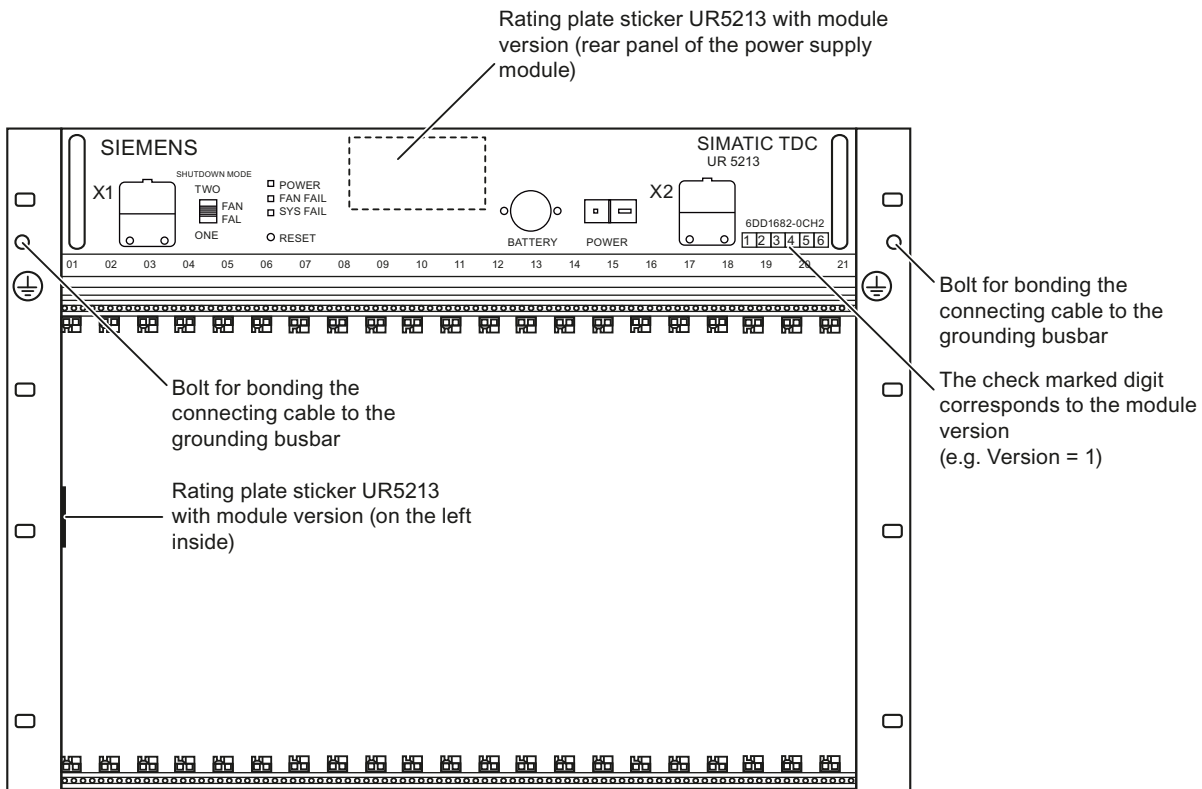

Figure 4-7 Rack UR5213 (front view)

PS5213 power supply

The power supply with three fans is inserted and screw mounted in the upper section of the rack.

4.3.3 Control and display elements

X1

3 signaling relays, 230 V floating potential (3 x 2 contacts)

SHUTDOWN MODE

A system stop triggered by fan failure can be set based on the switch position, i.e. "ONE" setting for failure of one fan, or "TWO" setting for failure of two fans.

LED

The three LEDs display the rack's operating status.

RESET

You can restart all modules by pressing the submerged pushbutton (rack RESET).

BATTERY

Compartment for backup batteries
(2 x 1.5 V leak-proof alkaline manganese cells type AA)

POWER

Mains switch

X2

Line voltage connection

Front panel

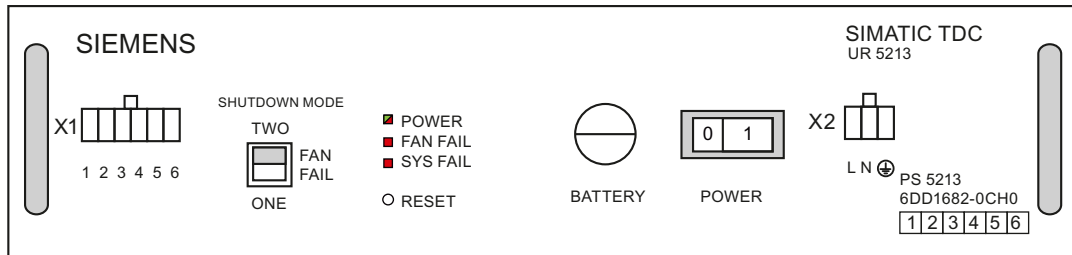

Figure 4-8 Front view of the power supply unit

4.3.4 Status and fault displays

Table 4-4 Status displays for UR5213

LED	Display	Rack state
POWER (green or red)	green is on	fault-free operation
	red is on	fault (refer to voltage monitoring)
FAN FAIL (red)	Off	fault-free operation
	On	fault (at least one fan has failed)
SYSFAIL (red)	Off	fault-free operation
	On	System was stopped

4.3.5 Power supply

Mains connection

Mains is connected to the 3-pin screw terminal block on the right side of the power supply unit.

The pin assignment is printed onto the front panel.

Input voltage	90 - 264 V AC Derating 85 – 90 V
Dielectric strength	1500 V AC 3000 V AC 500 V AC
• Mains inlet / PE • Mains inlet / SELV • SELV / PE	
Power consumption	800 W (apparent power approx. 835 VA)
L	Phase conductor L
N	Neutral conductor N
	Ground conductor PE
External fuse (dimensioning)	In = 9 A Is = <50 A (inrush peak) The power supply is equipped with an internal 12 A fuse. This means that only the mains supply has to be fused. It is recommended to use a standard 16 A thermo magnetic circuit-breaker (B characteristic). Alternatively, a slow-acting fuse may be used.

 WARNING
The PE/ground conductor must be connected to the power supply. A PE/ground terminal on the rack is inappropriate. The PE/ground conductor must be green with yellow stripe (green/yellow).

4.3.6 Voltage monitoring

Input voltage

The input voltage is monitored for low level.

Input voltage	Reaction
Undervoltage < approx. 90 V	<ul style="list-style-type: none"> ACFAIL signal and CPU STOP, shutdown of output voltages <85V

Voltage dips ≤ 15 ms are buffered.

The power supply and therefore the system will be restarted on recovery from voltage dips to approx. 5 % of the rated mains voltage and a duration longer than approx. 3 seconds.

The power on/off sequence (e.g. generation of a RESET or SYSFAIL signal) corresponds to the reaction to manual operation of the mains switch.

The rack goes into standby state following voltage interruption of a duration shorter than approx. 3 and dip to no less than approx. 5 % of the rated mains voltage. A usual power off sequence precedes this state.

This state can only be cleared by cycling power off and on by means of the mains switch.

Output voltage

All output voltages are monitored (e.g. for overload/short-circuit).

Voltage monitoring functions at the power supply outlet	Reaction
+5 V in the range from 4.75 V to 5.35 V	"POWER OK" LED is lit green;
+ 3.3 V in the range from +3.18 V... +3.5 V + 12 V in the range from +11 V to +13 V - 12 V in the range from -11 V to -13 V	

In all other cases, the "POWER OK" LED is lit red.

System failure alarm

Select the "Object properties" in the "STOP" tab of **HWConfig** to configure the response of the relevant module to a system failure alarm (bus signal ***SYSFAIL**=low):

- Modules can reset their digital and analog outputs
- CPU modules can go into the "STOP" state ("H" is displayed permanently)

4.3.7 Battery backup

Battery connection

In order to backup configured values to memory on power failure (using the SAV function blocks), you need to install two commonly available size AA leak-proof alkaline manganese batteries with a rated voltage of 1.5 V in the power supply circuit.

It is recommended to replace the batteries at annual intervals.

The backup function is no longer available if you remove the power supply unit (e.g. in the case of malfunction, or fan replacement).

Battery voltage monitoring

The CPU module inserted in slot 1 detects missing or low backup batteries and signals these states with a flashing "b".

Battery replacement

You should always replace the battery while the rack is powered on in order to prevent data loss.

Note that **while installing** the battery you also need to take corresponding **measures** in preparation for its **replacement**.

4.3.8 Ventilation/cooling

The PS5213 power supply is equipped with three fans.

Since the rack is not equipped with an air filter, you should provide a filter on the cabinet if necessary.

Fan monitoring

The fans are monitored (speed). Activation of the monitoring function is delayed in order to enable the reliable startup of the rack after you switched on power.

On failure of one or two fans, the power supply is shut down in order to prevent thermal destruction of the modules. Use the "Shutdown Mode" dip switch to select the mode (the switch has the "ONE" or "TWO" settings). With switch position "ONE", a power supply shutdown is triggered on failure of at least one fan and in switch position "TWO" by the failure of at least two fans.

WARNING

Always set the "Shutdown mode" dip switch S1.4 to "ONE" for modules requiring forced convection (e.g. CPU550) at air intake temperatures from 0 °C to 55 °C.

You may only set switch position "TWO" if it can be assured that the air intake temperature at the rack does not exceed 35 °C. The power supply is not shut down on failure of a single fan, but the corresponding backplane bus signal (FANAL*) is activated and can be detected by the configuration software.

Fan replacement

At an ambient temperature of 55 °C, it is recommended to replace the fans at intervals of approx. **40,000 operating hours**. The power supply must be removed for fan replacement. Users cannot replace the fans.

Signaling relay

Three 230V signaling relays with floating potential facilitate external evaluation of the rack's system states.

Table 4-5 Signaling relay

Signaling relay	Terminal X1	Contact in switched off state	Contact in error-free operation	LED in error-free operation
SYSFAIL	1,2	Closed	Closed	Off
POWER	3,4	Open	Closed	green is on
FAN FAIL	5,6	Open	Closed	Off

4.3.9 Technical specifications

Article number

Rack UR5213	6DD1682-0CHO
-------------	--------------

General data

Safety	EN 61131-2
Degree of protection	IP 20
Protection class	Protection class 1 with PE/ground conductor

Storage temperatures	-40 °C to +70 °C
Operating temperatures	0 °C to +55 °C
Relative air humidity	5 % to 95 %, no condensation
Atmospheric pressure	Operation: 1080 hPa to 795 hPa Storage: 1080 hPa to 660 hPa

Power input

Input voltages (AC)	90 V - 264 V
Rated input current	Typically < 10 A
Max. inrush current	<< 50 A
Frequency	47 Hz to 63 Hz
Power factor	EN 61000-3-2
Power failure backup	min. 15 ms

Output voltages

Rated output voltage	Output current
+5 V	60 A
+3.3 V	60 A
+12 V	8 A
-12 V	8 A

All outputs are sustained short circuit-proof and **do not** need a basic load.

Battery

Current load	approx. 10 µA for each inserted CPU module
--------------	--

Dimensions

Number of rack slots	21
Dimensions W x H x D [mm]	approx. 482.6 x 354.9 x 343
Weight	Approx. 20 kg

4.4 Slot covers

Application

Slot cover SR51 is used to protect unused slots of the rack. This is necessary to ensure proper ventilation and EMC compatibility of the system.

Article number

Slot cover SR51	6DD1682-0DA1
-----------------	--------------

CPU modules

5.1 CPU module CPU555

5.1.1 Areas of application

CPU555 is a graphically freely configurable processor module, enabling the implementation of sophisticated highly dynamic control functions.

Use cases include:

- Roll nip controls
- Hydraulic positioning functions
- Strip cooling systems
- HVDCT control systems (high voltage DC transmission)

NOTE

Note the following for the CPU555:

- CPU555 can only be used in the rack UR6021. A maximum of eight CPU555 can be inserted in one UR6021.
- CPU555 can only be configured with a version V8.1 or higher of the D7-SYS automation software.
- The floating point unit used supports Floating Point data types, operations and exception handling as defined in IEEE Standard 754 (2008). Floating point numbers are calculated internally with 80 bits. This results in fewer rounding errors as compared to calculations with only 64 bits (CPU551).
- The CPU555 does not apply substitute values for invalid real values. This method provides higher performance. Typically, invalid real values result from corrupted data from external interfaces. Calculating with invalid real values can have unintended results. Checking the input values with the CHK_R function block is recommended. With the CHK_R function block, you can assign a substitute value for an error scenario.

NOTE

Note the following for operation with other CPUs:

- Operation of the CPU555 together with a CPU551 is **not** approved.
 - Operation of the CPU555 together with a CPU550 is **not** approved.
-

NOTE**Note the following for operation with modules:**

- Operation of the CPU555 with the CP5100 and CP50M0 modules that are being phased out is not possible.
 - Use of a CP50M1 in combination with a CPU555 is only possible as of a firmware version ≥ 4
 - Use of a CP51M1 in combination with a CPU555 is only possible as of a functional status ≥ 8
 - Use of a CP52A0 with article number 6DD1660-0BH0 in combination with a CPU555 is only possible as of a functional status ≥ 9
 - Use of a CP53M0 in combination with a CPU555 is only possible as of a functional status ≥ 9
 - Use of an SM500 in combination with a CPU555 is only possible as of a functional status ≥ 13
-

5.1.2 Control and display elements

LED display

The processor number, states and faults are displayed using a 5x7 dot matrix LED array.

Acknowledge button S1

This button has two functions:

- Clearing the fault display:
The acknowledge button can be used to clear sporadic or non-critical fault displays on the 5x7 dot matrix LED. An additional fault is displayed after the first one has been acknowledged.
- Digital signal input can be evaluated using the **ASI** function block.

Front panel

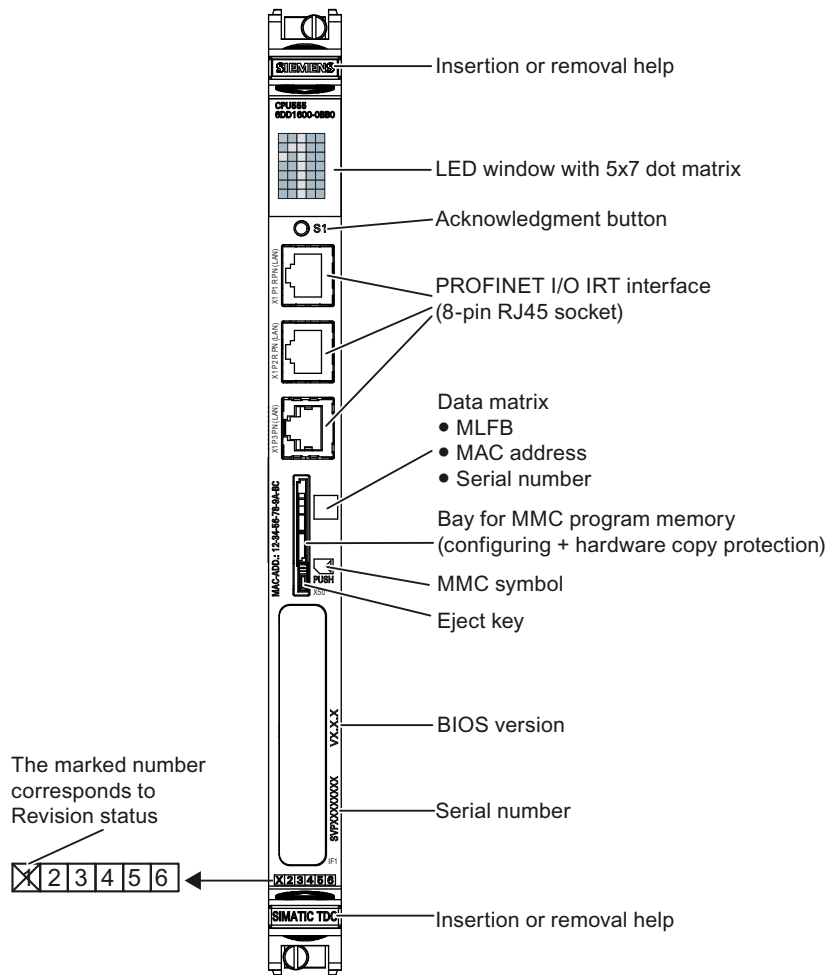

Figure 5-1 Front view of CPU555

5.1.3 Status and fault displays

The dot matrix shows the configured number of the CPU module (1 to 20) in normal operation. Faults are indicated by a letter that informs you of the type of fault.

Slow alternation between the light and dark state of the dot matrix is referred to as flashing in the following table.

Table 5-1 Operating and fault states of CPU555

Display	Operating and fault states	Can be cleared with S1
1...20	Configured number of the CPU module in normal operation. User program is running	No
A	User error User program is running Diagnostics event, user-defined by means of USF function block	Yes

Display	Operating and fault states	Can be cleared with S1
All 35 dots off	Initialization phase: User program is not running Individual initialization phases during startup are indicated by means of a colored circle and consecutive numbers.	No
All 35 dots flashing	Module failure: User program is not running <ul style="list-style-type: none"> • Hardware failure => replace CPU555 • Fatal software error => contact the Hotline 	No
All 35 dots on	Partial power failure, FPGA1 failure or errors on the module: User program is not running <ul style="list-style-type: none"> • Hardware failure => replace CPU555 • Fatal hardware fault => contact the Hotline 	No
Colored circle flashing	Initialization phase: User program is not running	No
0	Initialization error User program is not running Diagnostics should start at the CPU module that was the first to display fault message "0". <ul style="list-style-type: none"> • Flashing "0" Faults on this module • Permanent "0": Faults on a different module If none of the CPU modules can be identified as having been the first one, then the one inserted to the extreme left should first be selected of those which display a "0".	No
b	Monitoring error User program is running Low-priority errors during initialization that allow the start of normal operation and that are detected in the background process, e.g.: e.g. <ul style="list-style-type: none"> • missing or low backup battery • Missing program memory module • Fan failure • Invalid real value 	Yes
C	Communication error User program is running Incorrect configuration of communication, or connection error For more information on diagnostics functions, refer to the manual "D7-SYS - STEP 7, CFC and SFC configuring (http://support.automation.siemens.com/WW/view/de/8776786/0/en)", chapter Basic software, section "Diagnostics". (Initial error = flashing; additional errors = continuous display)	No
d	User stop User program is not running Selection in the "Target system/Operating state" menu User stop results in a stop of all CPUs in the same rack. <ul style="list-style-type: none"> • Permanent "d": Module is in STOP, triggered by another CPU. • Flashing "d" Module is in STOP, triggered by this CPU itself. 	No

Display	Operating and fault states	Can be cleared with S1
E	<p>Task Manager error User program is running</p> <ul style="list-style-type: none"> Flashing "E": Initial error Permanent "E": Subsequent error after a lower priority error <p>The following errors are possible:</p> <ul style="list-style-type: none"> <i>Cycle errors</i> A task could not be completed within the sampling time. <i>Task overflow</i> If a task that has not been not assigned top priority but needs to be restarted. <i>No free local buffer</i> The data buffer is no longer released. The task start will be skipped. <i>Software time monitoring</i> If the basic sampling time is not processed four times in succession. The basic clock cycle timer is re-initialized with the configured basic sampling time and processing is continued. <p>For more information on diagnostics functions, refer to the manual "D7-SYS - STEP 7, CFC and SFC configuring (http://support.automation.siemens.com/WW/view/de/8776786/0/en)", chapter Basic software, section "Diagnostics".</p>	Yes
H	<p>System error User program is not running Hardware or software problems causing a program crash.</p> <ul style="list-style-type: none"> Flashing "H" Faults on this module Permanent "H": Faults on a different module <p>For more information on diagnostics functions, refer to the manual "D7-SYS - STEP 7, CFC and SFC configuring (http://support.automation.siemens.com/WW/view/de/8776786/0/en)", chapter Basic software, section "Diagnostics".</p>	No
P	<p>PROFINET IO fault There is a serious fault (e.g. line failure) on the PN bus. The cause of the error is described in greater detail in the module state of the CPU and in the diagnostics buffer. Possible causes:</p> <ul style="list-style-type: none"> PNIO cable pulled (Slave) device name not yet assigned Missing connection in topology (e.g. after module replacement, PNIO cable in wrong port) Device removed Wrong module configured or module not present Triggering of diagnostic interrupts in the device Wrong firmware on the device <p>Note: This display is available as of D7-SYS V8.2.</p>	No, this error display clears automatically when the cause of the error has been resolved

5.1.4 Application notes and immunity to interference

- Fan operation is necessary.
- Interference-proof operation is only possible if the CPU555 is firmly attached to the rack. Insert the module and then bolt it onto the rack accordingly (two screw heads, see "Control and display elements (Page 77)").
- The module may not be inserted or removed while the rack is on live voltage.
- A CPU must be inserted into the first slot of the rack.

NOTICE**CPU555 in the UR6021 rack**

CPU555 may only be used in the rack UR6021.

No CPU555 may be inserted in slot 21 when the UR6021 rack is used.

NOTE

For more information on fan operation, refer to section "Rack (Page 43)".

For more information on EMC and environmental conditions, refer to section "General technical specifications (Page 41)".

NOTE**Shutdown behavior of various CPU modules**

The various CPU modules exhibit slight time differences in their shutdown behavior when the power supply is interrupted.

5.1.5 Connection options

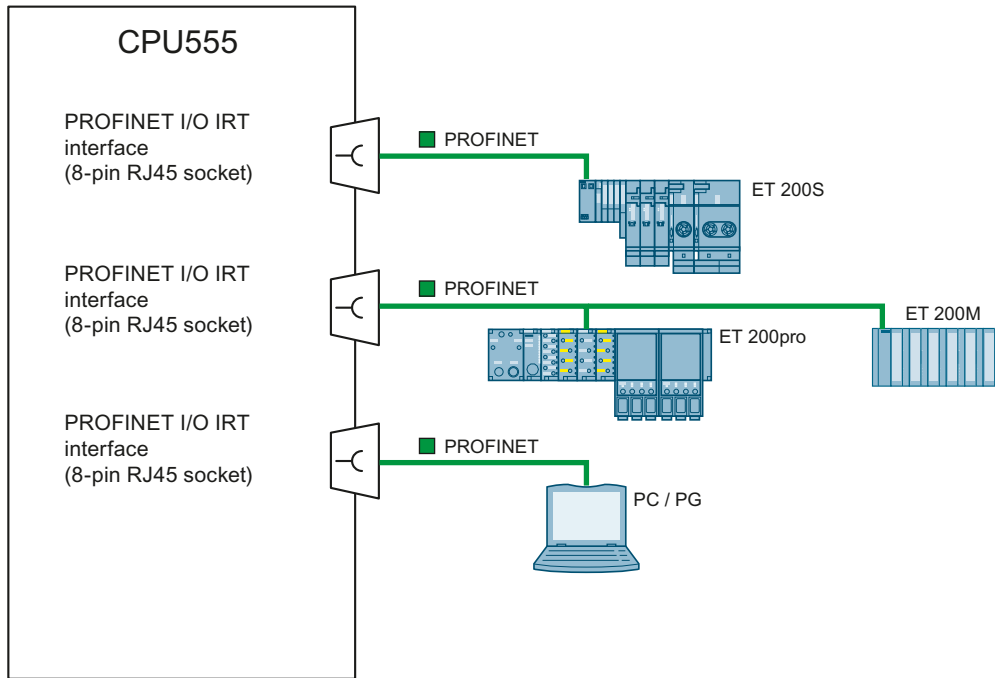

Figure 5-2 Connection examples of CPU555

5.1.6 Additional components

Table 5-2 Additional components for CPU555

Component	Designation	Article No.
Program memory (2 MB)	S7 MICRO MEMORY CARD	6ES7953-8LL31-0AA0
Program memory (4 MB)	S7 MICRO MEMORY CARD	6ES7953-8LM31-0AA0
Program memory (8 MB)	S7 MICRO MEMORY CARD	6ES7953-8LP31-0AA0

Table 5-3 Connecting cable

Designation	Article No.
SIMATIC NET, Industrial Ethernet TP XP CORD RJ45/RJ45, dressed with 2 x RJ45 connectors, length ...	6XV1870-3R...

For information on additional products, refer to: Product catalog

(<https://eb.automation.siemens.com>)

5.1.7 Pin assignments

PROFINET I/O interface (X1 P1 R PN (LAN), X1 P2 R PN (LAN), X1 P3 PN (LAN))

The PROFINET I/O IRT connection (10/100 Mbps) is connected to the 8-pole RJ-45 plug socket with polarity reversal protection.

Table 5-4 Pin assignment of X1 P1 R PN (LAN), X1 P2 R PN (LAN), X1 P3 PN (LAN) (RJ-45 socket)

PIN	Designation
1	TXP (Transmit Data +)
2	TXN (Transmit Data -)
3	RXP (Receive Data +)
4	n.c.
5	n.c.
6	RXN (Receive Data -)
7	n.c.
8	n.c.
Enclosure	PE (shield)

5.1.8 Note on firmware update

NOTE

Updating the firmware

- Firmware updates are available, if needed, on the Internet (<http://www.siemens.com/automation/service&support>) under "Downloads".
- Check regularly if firmware updates are available.

Always install the latest firmware on the CPU555 to receive the latest security updates and feature enhancements.

NOTICE

No firmware update during operation

Note that a firmware update cannot take place during operation but only at plant standstill.

NOTICE

Qualified Personnel

Only qualified personnel are permitted to perform the firmware update (see Qualified personnel (Page 13))!

NOTE**Requirements**

The following is required for a firmware update:

- USB flash drive with a memory capacity between 1 GB and 32 GB (FAT32)
- USB 2.0 type Mini-B to USB 2.0 type A adapter; approx. 20 cm

Table 5-5 Operating states of the CPU555 during the firmware update

Display	Operating state
Initialization phase	
■	LED test (approx. 1 sec)
●	Firmware start (flashing)
0	Operating system start
1...9	Operating system initialization / Startup
Update	
F	Firmware update in progress (F flashing)
✓	Firmware update completed

5.1.9 Using CPU555 firmware V1.1

Functions of the firmware V1.1

CPU555 V1.1 offers expanded functionality in addition to the V1.0 functions. To use this functionality, you need to configure the CPU as CPU555 V1.1 in D7-SYS V8.2 (HW Config).

The V1.1 functions are:

- Network routing across module racks
- Diagnostics via HW Config
- Full compatibility with V1.0 (replacement part scenario)

Firmware update

You can find firmware updates for the CPU555 as downloads on the Internet (<https://support.industry.siemens.com/cs/ww/en/view/109740119>).

5.1.10 Technical specifications/performance features

NOTE
CPU555 in the UR6021

The CPU module CPU555 can only be operated in the rack UR6021.
UR6021 can be equipped with a maximum of eight CPU555.

Article number

CPU module CPU555	6DD1600-0BB0
-------------------	--------------

CPU

Processor	64-bit Intel CPU
Clock frequency	2 GHz

Communications processor	32-bit CPU
Clock frequency	450 MHz

NOTE
Removal and insertion

Removal and insertion of the module is not permitted during operation.

Processor

SDRAM	2 GB DDR3-1333 MHz (667 MHz)
Caches	<ul style="list-style-type: none"> • L1 cache: 32 KB data + 32 KB instruction • L2 cache: 256 KB data/instruction • L3 cache: 3 MB

Communications processor

SDRAM	256 MB DDR2-400 (150 MHz)
Cache	<ul style="list-style-type: none"> • L1 cache: 32 KB data + 32 KB instruction

Shared communication memory

SRAM (battery buffered)	1 MB
-------------------------	------

Module slots

Quantity	3
Allocation of the slots	<ul style="list-style-type: none"> • Program memory S7 MMC (X4) • PMC-/XMC plug-in cards (X5) ¹⁾
¹⁾ PMC/XMC plug-in cards are currently not provided.	

Time

Resolution	0.1 ms
------------	--------

Fast CPU-CPU communication

CPU555 supports P0 functionality.

Each CPU555 can communicate with up to 7 additional CPU555 by means of the PCIe interface via the backplane bus (P0 connector). This means that a point-to-point connection always exists between any two CPU555 modules (see Areas of application [\(Page 43\)](#)).

Programming

The user program executed on the CPU module is configured on a PC using STEP 7 / HW Config and CFC and then downloaded to program memory.

The program memory must be located in the CPU module slot provided (X4).

Direct user program download from the PC to program memory in the CPU module via PROFINET interface (online loading).

User program size

The size of the user program (compressed to approx. 50 %) that was downloaded to program memory and the size of free program memory can be viewed in the CFC by selecting the following menu command:

- PLC / Load / Info

Utilization

Average load (measured with block PSL) should not exceed 90%, since this may lead to sporadic overload.

Program memory

The user program created in CFC is downloaded to program memory. Program memory features Flash EPROM (2, 4 or 8 MB).

Program memory for user program: See Additional components [\(Page 82\)](#)

PROFINET interfaces

LAN interfaces <ul style="list-style-type: none"> • Support of distributed I/O • Operator control and monitoring • Communication with a PC • Download function • TCP/UDP communication with other CPUs • Set time of day <p>The frame length is restricted as follows:</p>		PROFINET I/O interfaces ¹⁾ <ul style="list-style-type: none"> • X1 P1 R PN (LAN): 10/100 Mbps • X1 P2 R PN (LAN): 10/100 Mbps • X1 P3 PN (LAN): 10/100 Mbps
Protocol	User data length for transmit and receive mode, respectively	
TCP	32767 bytes	
UDP	send 1490 bytes receive 1472 bytes	

1) All X1 interfaces have the same IP address

I/O address range

Inputs	8192 bytes
Outputs	8192 bytes

Process image partition

Quantity	1
Address range	
Inputs, max.	8192 bytes
Outputs, max.	8192 bytes

Voltage, currents

Rated voltages at 25 °C	Typical current consumption
+5 V	4.26 A (max. 7.98 A)
+3.3 V	2.94 A (max. 3.95 A)
Backup battery	3 µA (max. 27 µA)

Power losses/fan

Typical power losses (5 V / 3.3 V)	31 W (21,3 W / 9,7 W)
Fan required	Yes

Dimensions

Number of slots required in the rack	1
Dimensions W x H x D [mm]	20 x 233 x 160
Weight	0.6 kg

Degree of protection

Degree of protection according to DIN 40050	IP00
---	------

5.2 CPU module CPU550/CPU551**5.2.1 Areas of application**

The CPU550/CPU551 processor module can be customized by means of graphic interface and enables the realization of demanding, highly dynamic automatic control systems.

Use cases include:

- Roll nip controls
- Hydraulic positioning functions
- Strip cooling systems

5.2.2 Using the CPU551 - 6DD1600-0BA3

Please note the following when using the CPU module CPU551 with the article number 6DD1600-0BA3.

Configuration

NOTE**Configuration**

- Up to D7-SYS V8.0: To configure the CPU module CPU551 "6DD1600-0BA3" in HW Config, select the CPU551 "6DD1600-0BA2".
 - For system and communications configuration, select SIMATIC D7-SYS as of V5.2.
 - Only use memory cards whose configuration was created with SIMATIC D7-SYS as of V5.2.
-

Operation with CP53M0

NOTE**CPU551 with CP53M0**

To operate the CPU module CPU551 (6DD1600-0BA3) with the communications module CP53M0, use only a communications module CP53M0 with a **functional status > 5**.

Operation with CP51M1

NOTE**CPU551 with CP51M1**

To operate the CPU module CPU551 (6DD1600-0BA3) with the communications module CP51M1, use only a communications module CP51M1 with a **functional status > 7**.

Substitute value behavior

NOTE**Floating decimal calculation**

Please note that if you have selected the option "Use substitute values for invalid Real values" that the calculation with invalid Real values (NaN) can return different results with versions 6DD1600-0BA1 and 6DD1600-0BA2 of CPU module CPU551.

5.2.3 Control and display elements

LED display

The processor number, states and faults are displayed using a 5x7 dot matrix LED array.

Acknowledge button S1

This button has two functions:

- Clearing the fault display:

The acknowledge button can be used to clear sporadic or non-critical fault displays on the 5x7 dot matrix LED. An additional fault is displayed after the first one has been acknowledged.

- Digital signal input can be evaluated using the **ASI** function block.

Front panel

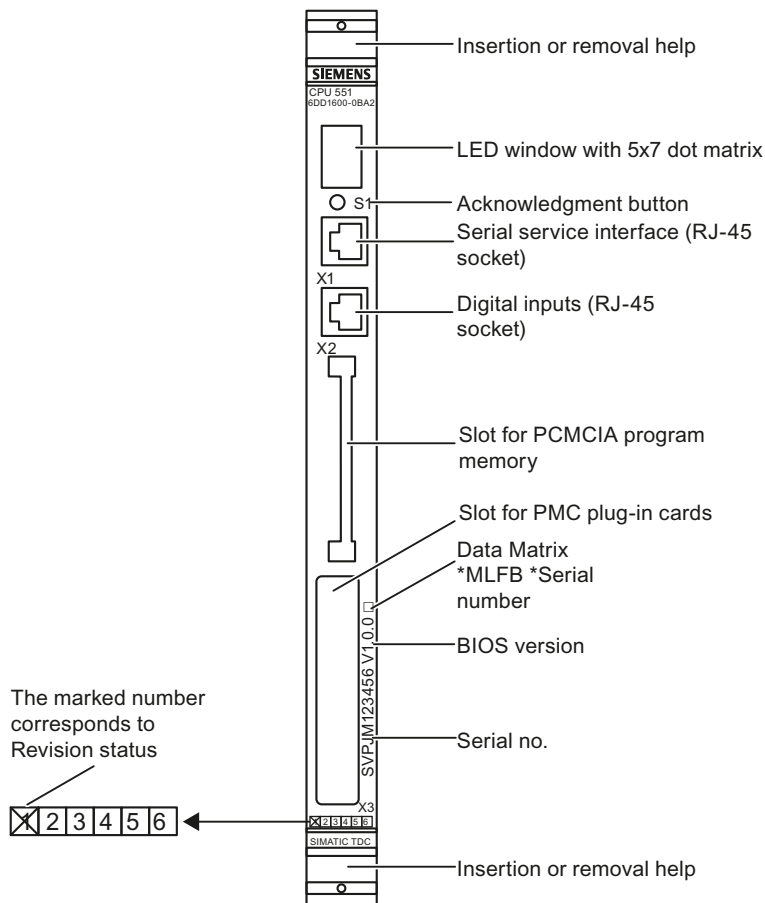

Figure 5-3 Front panel of CPU551

5.2.4 Status and fault displays

The configured number of the CPU module (1...20) is displayed in normal operation. Faults are indicated by a letter that informs you of the type of fault.

Slow alternation between the lit and dark state of the 5x7 dot matrix LEDs is referred to as flashing in the following table.

NOTE

Maximum insertions

A maximum of 20 CPU551 can be plugged into one rack. When GDM coupling is used, a maximum of 19 CPU551 can be inserted in one rack because a CP52A0 is needed for rack coupling.

Table 5-6 Operating and fault states of CPU550/CPU551

Display	Operating and fault states	Can be cleared with S1
1... 20	Configured number of the CPU module in normal operation. User program is running	No
A	User error User program is running Diagnostics event, user-defined by means of USF function block	Yes
All 35 dots off	Initialization phase: User program is not running Individual initialization phases during startup are indicated by means of consecutive numbers.	No
All 35 dots flashing	Module failure: User program is not running <ul style="list-style-type: none"> Hardware failure => replace CPU550/CPU551 Fatal software error => contact the Hotline 	No
0	Initialization error User program is not running Diagnostics should start at the CPU module that was the first to display fault message "0". <ul style="list-style-type: none"> Flashing "0" Faults on this module Permanent "0": Faults on a different module If none of the CPU modules can be identified as having been the first one, then of those which display a "0", the one inserted to the extreme left should first be selected.	No
b	Monitoring error User program is running Low-priority errors during initialization that allow the start of normal operation and that are detected in the background process, e.g.: For example, <ul style="list-style-type: none"> missing, low backup battery Missing program memory module Fan failure Invalid floating value (substitute value will be used) 	Yes

Display	Operating and fault states	Can be cleared with S1
C	<p>Communication error User program is running Incorrect configuration of communication, or connection error For more information on diagnostics functions, refer to the manual "D7-SYS - STEP 7, CFC and SFC configuring", chapter Basic software, section "Diagnostics".</p>	No
d	<p>User stop (not with CPU550) User program is not running User stop results in a stop of all CPUs in the same rack.</p> <ul style="list-style-type: none"> • Permanent "d": Module is in STOP, triggered by another CPU. • Flashing "d" Module is in STOP, triggered by this CPU itself. 	No
E	<p>Task Manager error User program is running</p> <ul style="list-style-type: none"> • Flashing "E": Initial error • Permanent "E": Subsequent error after a lower priority error <p>The following errors are possible:</p> <ul style="list-style-type: none"> • <i>Cycle errors</i> A task could not be completed within the sampling time. • <i>Task overflow</i> If a task that has not been not assigned top priority needs to be restarted. • <i>No free local buffer</i> The data buffer is no longer released. The task start will be skipped. • <i>Software time monitoring</i> If the basic sampling time is not processed four times in succession. The basic clock cycle timer is re-initialized with the configured basic sampling time and processing is continued. <p>For more information on diagnostics functions, refer to the manual "D7-SYS - STEP 7, CFC and SFC configuring" (http://support.automation.siemens.com/WW/view/de/8776786/0/en), chapter Basic software, section "Diagnostics".</p>	Yes
H	<p>System error User program is not running Hardware or software problems causing a program crash.</p> <ul style="list-style-type: none"> • Flashing "H" Faults on this module • Permanent "H": Faults on a different module <p>For more information on diagnostics functions, refer to the manual "D7-SYS - STEP 7, CFC and SFC configuring" (http://support.automation.siemens.com/WW/view/de/8776786/0/en), chapter Basic software, section "Diagnostics".</p>	No

5.2.5 Application notes and immunity to interference

- Fan operation is necessary.
- Interference-proof operation is only possible if the CPU550/CPU551 is firmly attached to the rack. Insert the module and then bolt it onto the rack accordingly (two screw heads, see "Control and display elements (Page 90)").
- The module may not be inserted or removed while the rack is on live voltage.
- A CPU must be inserted into the first slot of the rack.

NOTE

For more information on fan operation, refer to chapter "Rack (Page 43)".

For more information on EMC and environmental conditions, refer to chapter "General technical specifications (Page 41)".

NOTE

Shutdown behavior of various CPU modules

The various CPU modules exhibit slight time differences in their shutdown behavior when the power supply is interrupted.

5.2.6 Connection options

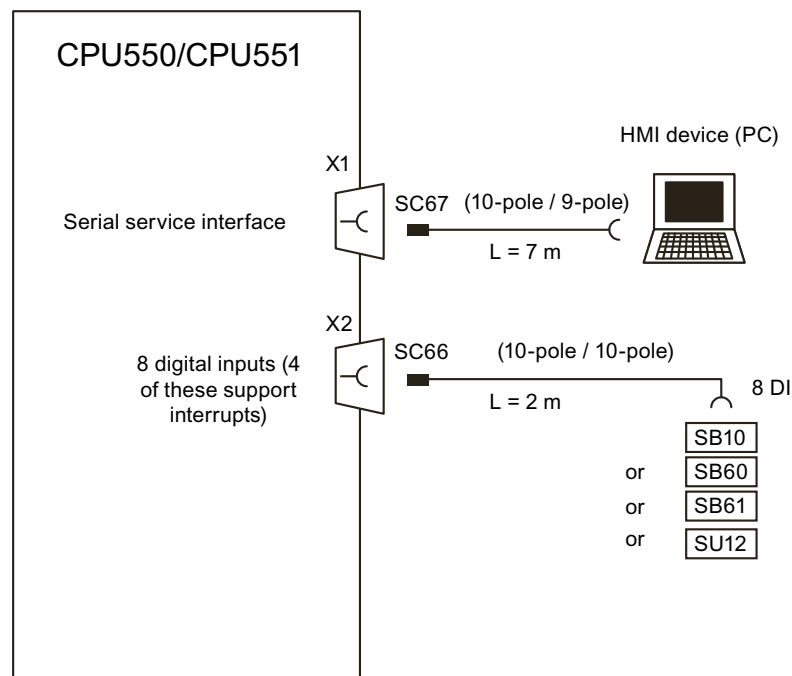

Figure 5-4 Connection options of CPU550/CPU551

5.2.7 Additional components

Table 5-7 Additional components for CPU550/CPU551

Component	Designation	Article number
Program memory (4 MB)	MC 500	6DD1610-0AH4
Program memory (8 MB)	MC 510	6DD1610-0AH6
Program memory (2 MB)	MC 521	6DD1610-0AH3
PC connecting cable (10-pole/9-pole)	SC67	6DD1684-0GH0
Cable for digital inputs (10-pole/10-pole)	SC66	6DD1684-0GG0
Interface module Electrical 1:1 wiring, no signal conversion	SB10	6DD1681-0AE2
Interface module with electrical isolation and signal conversion	SB60	6DD1681-0AF4
Interface module with electrical isolation and signal conversion	SB61	6DD1681-0EB3
Interface module Electrical 1:1 wiring, no signal conversion	SU12	6DD1681-0AJ1

5.2.8 Pin assignments

Serial service interface (X1)

An control or configuration PC is connected to the 10-pin RJ-45 socket with polarity reversal protection using the SC67 PC cable.

Table 5-8 Pin assignment of X1 and cable SC67

X1		SC67	
PIN	Designation	PIN CPU side	PIN PC side
1	DCD (Data Carrier Detect)	n.c.	n.c.
2	RxD (Receive Data)	2	3
3	TxD (Transmit Data)	3	2
4	DTR (Data Terminal Ready)	n.c.	n.c.
5	GND (Ground)	5	5
6	DSR (Data Set Ready)	n.c.	n.c.
7	RTS (Request to Send)	n.c.	n.c.
8	CTS (Clear to Send)	n.c.	n.c.
9	RI (Ring Indicator)	n.c.	n.c.
10	(n.c.)	n.c.	
n.c.: n.c.			

Digital inputs (X2)

An interface module is connected to the 10-pin RJ-45 socket with polarity reversal protection via cable SC66.

Table 5-9 Pin assignment X2 and cable SC66

X2		SC66	
PIN	Designation	PIN CPU side	PIN PC side
1	Ground	n.c.	n.c.
2	Digital input 0 (supports interrupts)	2	1
3	Digital input 1 (supports interrupts)	3	2
4	Digital input 2 (supports interrupts)	4	3
5	Digital input 3 (supports interrupts)	5	4
6	Digital input 4	6	5
7	Digital input 5	7	6
8	Digital input 6	8	7
9	Digital input 7	9	8
10	Ground	10	10
n.c.: n.c.			

5.2.9 Technical specifications/performance features

Article number

CPU module CPU550	6DD1600-0BA0
CPU module CPU551	6DD1600-0BA1 / 6DD1600-0BA2 / 6DD1600-0BA3

The CPU modules CPU551 with the article numbers 6DD1600-0BA1 and 6DD1600-0BA2 have been replaced by the modules with the article number 6DD1600-0BA3.

NOTE

Where two different values are specified for a feature (separated by "/") in the manual, the first is valid for the module with article number 6DD1600-0BA1 and the second for the module with article number 6DD1600-0BA2 and the third for modules with the article number 6DD1600-0BA3.

CPU

CPU	6DD1600-0BA1		
		6DD1600-0BA2	
			6DD1600-0BA3
Processor	64 bit RISC processor		
Clock frequency	266 MHz	500 MHz	800 MHz

Memory

CPU	6DD1600-0BA1		
		6DD1600-0BA2	
			6DD1600-0BA3
SDRAM / DDR2-DRAM <ul style="list-style-type: none"> During initialization, the user program is loaded from program memory and expanded (Boot Flash is available separately) Data memory for the operating system, communication, message buffer, and Trace 	32 MB	128 MB	256 MB
SRAM Buffered SRAM (by means of external battery in the rack) contains the following data that must be backed up to retentive memory on power failure: <ul style="list-style-type: none"> Fault diagnostics of the operating system ("exception buffer") Max. 993 process variables configured with SAV function block Data recorded using the Trace function or the message system (SRAM can be optionally configured) 	256 KB	512 KB	512 KB
Synchronized L1 cache	64 KB	64 KB	64 KB
Synchronized L2 cache	ext. L2 cache	int. L2 cache	
	512 KB	256 KB	512 KB
Synchronized L3 cache	ext. L3 cache		int. L3 cache
	2 MB	8 MB	1 MB

Module slots

Quantity	3
Allocation of the slots	<ul style="list-style-type: none"> Program memory MC5xx PMC plug-in cards¹⁾
¹⁾ PMC plug-in cards are currently not provided.	

Time

Resolution	0.1 ms
------------	--------

Programming

The user program executed on the CPU module is configured on a PC using STEP7/HWConfig and CFC and then downloaded to program memory.

The program memory must be located in the CPU module slot provided.

There are two ways of loading the user program:

- **Offline download**

Carried out on the PC using an integrated or external PCMCIA programming adapter ("PC card").

- **Online download**

Direct user program download from the PC to program memory in the CPU module via serial service interface.

User program size

The size of the user program (compressed to approx. 50 %) that was downloaded to program memory and the size of free program memory can be viewed in the CFC by selecting the following menu command:

- PLC / Load / Info

Utilization

Average load (measured with block PSL) should not exceed 95 %, since this may lead to sporadic overload.

Program memory

The user program created in CFC is downloaded to program memory.

The following program memory may be used optionally, depending on the size of the user program:

- MC500 (4 MB)
- MC510 (8 MB)
- MC521 (2 MB)

Digital inputs

Quantity	8
Version	4 of the 8 digital inputs support alarms
Electrical isolation	No
Input voltage <ul style="list-style-type: none"> Rated voltage For 0 signal For 1 signal 	24 V -1 V to +6 V +13.5 V to +33 V
Input current <ul style="list-style-type: none"> For 0 signal, normally For 1 signal, normally 	0 mA 3 mA
Delay time per channel, max. (Minimum cycle during which alarm tasks can be triggered.)	100 μ s

Interfaces

Serial service interface (X1) <ul style="list-style-type: none"> Functions for the user program <ul style="list-style-type: none"> Testing and commissioning Loading the program Transmission rate 	RS232 interface (V.24) with CFC or "Basic commissioning" from the PC 19.2 Kbps
---	---

Communication

Communication functions	Local CPU coupling
Max. number of configured send/receive channels (independent of the protocol used)	1000

Voltage, currents

Rated voltages at 25 °C	Typical current consumption	
	6DD1600-0BA1 6DD1600-0BA2	6DD1600-0BA3
+5 V	1.5 A	1.3 A
+3.3 V	2.0 A	1.7 A
+12 V	40 mA	20 mA
-12 V	40 mA	20 mA
Backup battery	2.2 / 3 μ A	

Power losses/fan

	6DD1600-0BA1 6DD1600-0BA2	6DD1600-0BA3
Typical power losses	15 W	13 W
Fan required	Yes	

Dimensions

	6DD1600-0BA1 6DD1600-0BA2	6DD1600-0BA3
Number of slots required in the rack	1	
Dimensions W x H x D [mm]	20 x 233 x 160	
Weight	0.4 kg	0.5 kg

Signal modules

6.1 SM500 signal module

6.1.1 Areas of application

The SM500 signal module provides analog and digital I/O, as well as incremental and absolute encoder connections.

Use cases include:

- Central connection of drives
- Connection of analog and digital actuators and sensors
- Status display by means of integrated LEDs

6.1.2 Control and display elements

LED displays

The SM500 signal module is equipped with 8 LEDs. H1 and H2 provide information about the current module state.

Table 6-1 LED displays of signal module SM500

LED designation (color)	Function
H1 (green) and H2 (red)	Module status display
H3 (green) and H4 (green)	Can be controlled by means of function block BIQ8 (digital output).
H5 (green) and H6 (green)	
H7 (green) and H8 (green)	

Front panel

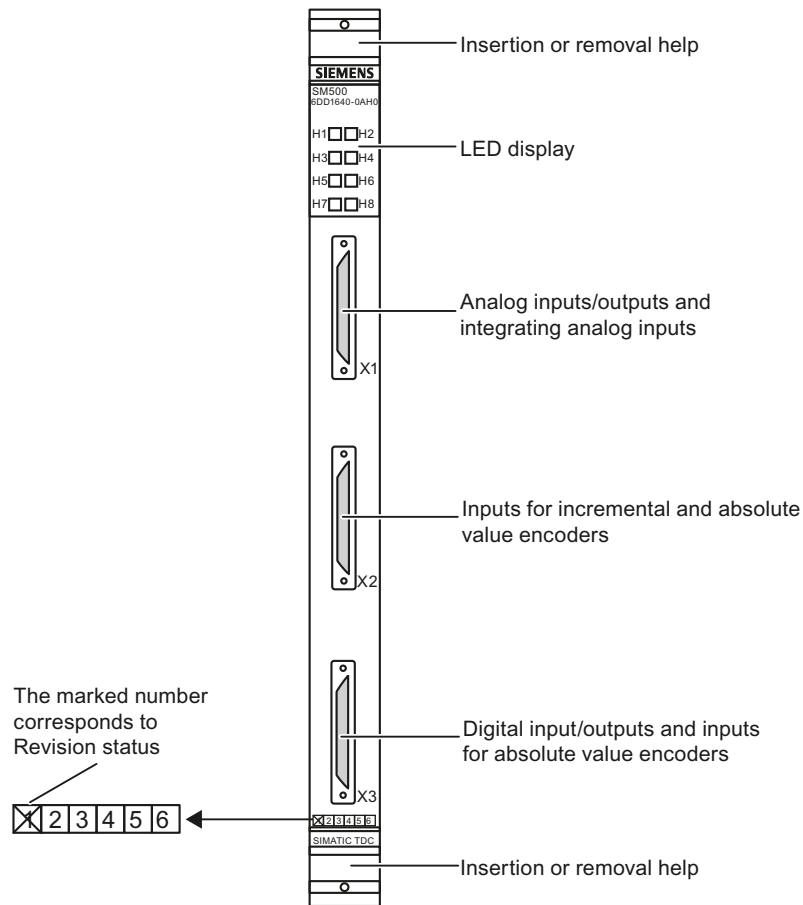

Figure 6-1 Front panel of SM500

6.1.3 Status and fault displays

Status displays for SM500

Table 6-2 Status displays for signal module SM500

LED display		Module status
H1	H2	
Off	Off	During voltage run-up
Off	On	FPGAs are configured, module is not initialized
On	Off	Module is initialized and operating error-free
On	On	After 3.3 V voltage failure <ul style="list-style-type: none"> Hardware failure => Power-down the rack and replace the SM500

6.1.4 Application notes and immunity to interference

- Fan operation is required
- Interference-proof operation is only possible if the SM500 is firmly attached to the rack. Insert the module and then bolt it onto the rack accordingly (two screw heads, see Control and display elements (Page 100)).
- The module may not be inserted or removed while the rack is on live voltage.

NOTE

For more information on fan operation, refer to chapter "Rack (Page 43)"!

For more information on EMC and environmental conditions, refer to chapter "General technical specifications (Page 41)"!

6.1.5 Connection options

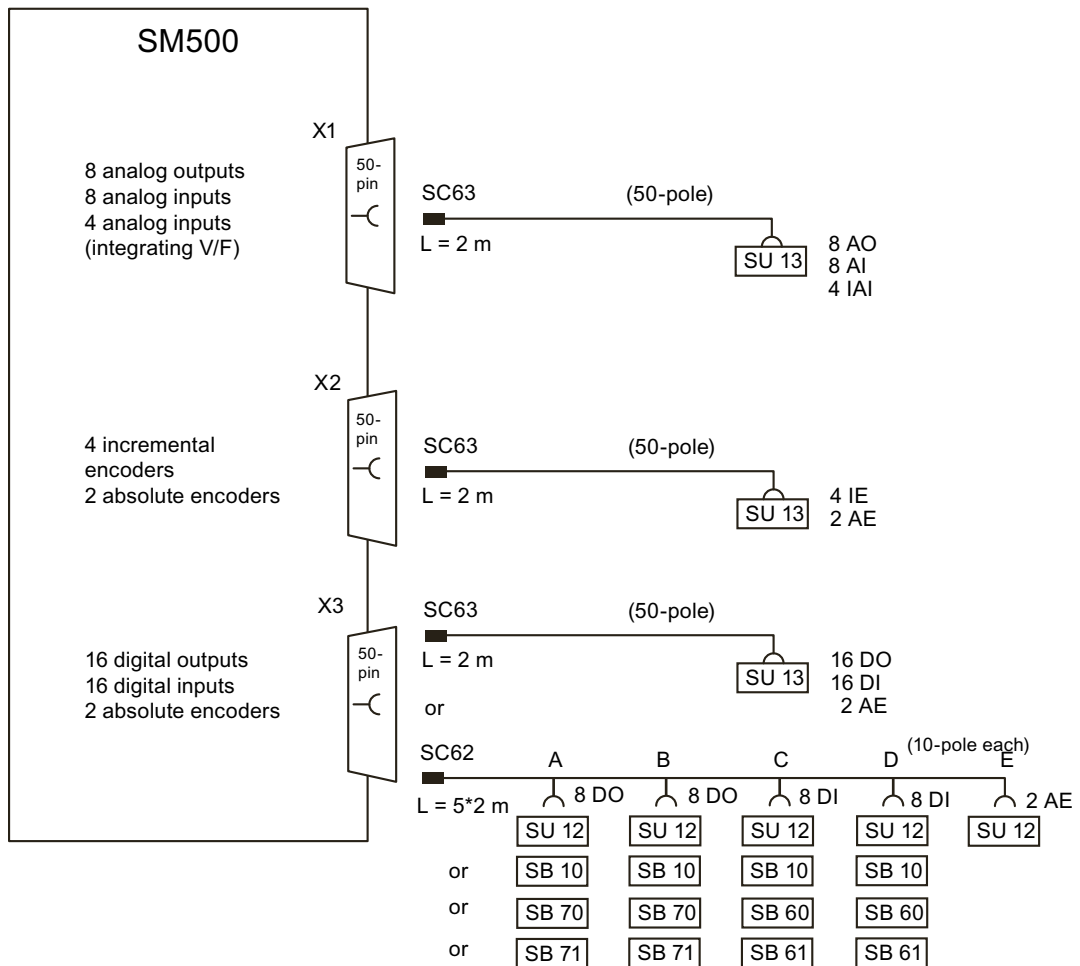

Figure 6-2 Connection options of SM500

6.1.6 Additional components

Table 6-3 Cables and interface modules for signal module SM500

Component	Designation	Article number
Cable for SM500 (50-pole/5*10-pole)	SC62	6DD1684-0GC0
Cable for digital inputs (50-pole/50-pole)	SC63	6DD1684-0GD0
Interface module Direct wiring (1:1 wiring), 10 screw terminals, no signal conversion	SU12	6DD1681-0AJ1
Interface module Direct wiring (1:1 wiring), 50 screw terminals, no signal conversion	SU13	6DD1681-0GK0
Interface module Direct wiring (1:1 wiring), 8 digital I/O, LED, no signal conversion	SB10	6DD1681-0AE2
Interface module 8 digital inputs, conversion, 120 V to 24 V (module signal level), LED, electrical isolation	SB60	6DD1681-0AF4
Interface module 8 digital inputs, conversion 48 V to 24 V, LED, electrical isolation	SB61	6DD1681-0EB3
Interface module 8 digital outputs, conversion, 24 V to 120 V (changeover relay), LED, electrical isolation	SB70	6DD1681-0AG2
Interface module 8 digital outputs, conversion 25 V to 48 V (transistor)	SB71	6DD1681-0DH1

6.1.7 Incremental encoder input settings

Depending on the type of encoder used (15 V or 5 V encoder), switches S1 and S2 must be set on the module corresponding to the following table.

Each track (A/VW, B/RW, NI-) of a channel has a switch that can be used to set the appropriate encoder type:

- Switch open (OFF):
15 V encoder, switching threshold 7 V
- Switch closed (ON):
5 V encoder, switching threshold 0 V

All tracks (A/VW, B/RW, NI-) of a channel must have the same switch setting for operation.

NOTE

If you are using a TTL incremental encoder you must note that you cannot switch the control input to TTL signals. The control input only reacts to a HTL level.

Settings for encoder type with switches S1 and S2

Table 6-4 Switch settings for 5 V and 15 V encoders

Channel	Track	Switches	15 V encoder	5 V encoder
Encoder 1	A/VW	S1, 1	OFF	ON
	B/RW	S1, 2		
	N/-	S1, 3		
Encoder 2	A/VW	S1, 4	OFF	ON
	B/RW	S1, 5		
	N/-	S1, 6		
Encoder 3	A/VW	S2, 1	OFF	ON
	B/RW	S2, 2		
	N/-	S2, 3		
Encoder 4	A/VW	S2, 4	OFF	ON
	B/RW	S2, 5		
	N/-	S2, 6		

The Switches S1.7 / S1.8 and S2.7 / S2.8 are without function.

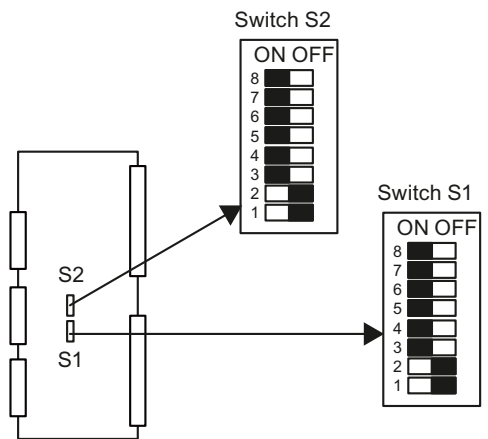

Position of switches S1 and S2 on the module

Switches S1 and S2 for setting the threshold for incremental encoders
(see encoder synchronization)

6.1.8 Pin assignments

Connection X1 with cable SC63

The assignment of the screw terminals at interface module SU13 corresponds to the connector assignment of X1.

Table 6-5 Pin assignment of X1

X1	Designation	SU13		X1	Designation	SU13
1	Analog output 1+	1		26	Analog output 5+	26
2	Analog output 1 -	2		27	Analog output 5 -	27
3	Analog output 2+	3		28	Analog output 6+	28
4	Analog output 2 -	4		29	Analog output 6 -	29
5	Analog output 3+	5		30	Analog output 7+	30
6	Analog output 3 -	6		31	Analog output 7 -	31
7	Analog output 4+	7		32	Analog output 8+	32
8	Analog output 4 -	8		33	Analog output 8 -	33
9	-	9		34	-	34
10	Ground, DA converter	10		35	Ground, DA converter	35
11	Analog input 1 +	11		36	Analog input 5 +	36
12	Analog input 1 -	12		37	Analog input 5 -	37
13	Analog input 2+	13		38	Analog input 6+	38
14	Analog input 2 -	14		39	Analog input 6 -	39
15	Analog input 3+	15		40	Analog input 7+	40
16	Analog input 3 -	16		41	Analog input 7 -	41
17	Analog input 4+	17		42	Analog input 8 +	42
18	Analog input 4 -	18		43	Analog input 8 -	43
19	-	19		44	-	44
20	Ground, AD converter	20		45	Ground, AD converter	45
21	Integrating analog input 1+	21		46	Integrating analog input 3 +	46
22	Integrating analog input 1-	22		47	Integrating analog input 3 -	47
23	Integrating analog input 2 +	23		48	Integrating analog input 4 +	48
24	Integrating analog input 2 -	24		49	Integrating analog input 4 -	49
25	Ground, analog input	25		50	Ground, analog input	50

Pin assignment X2 with cable SC63

The assignment of the screw terminals at interface module SU13 corresponds to the connector assignment of X2.

Table 6-6 Pin assignment of X2

X2	Designation	SU13		X2	Designation	SU13
1	Incremental encoder 1, track A+	1		26	Incremental encoder 2, track A+	26
2	Incremental encoder 1, track A-	2		27	Incremental encoder 2, track A-	27
3	Incremental encoder 1, track B+	3		28	Incremental encoder 2, track B+	28
4	Incremental encoder 1, track B-	4		29	Incremental encoder 2, track B-	29
5	Incremental encoder 1, track N+	5		30	Incremental encoder 2, track N+	30
6	Incremental encoder 1, track N-	6		31	Incremental encoder 2, track N-	31
7	Incremental encoder 3, track A+	7		32	Incremental encoder 3, track B+	32
8	Incremental encoder 3, track A-	8		33	Incremental encoder 3, track B-	33
9	Incremental encoder 3, track N+	9		34	Incremental encoder 3, track N-	34
10	Ground, encoder	10		35	Ground, encoder	35
11	Incremental encoder 4, track A+	11		36	Alarm input 1	36
12	Incremental encoder 4, track A-	12		37	Alarm input 2	37
13	Incremental encoder 4, track B+	13		38	Alarm input 3	38
14	Incremental encoder 4, track B-	14		39	Alarm input 4	39
15	Incremental encoder 4, track N+	15		40	Alarm acknowledgment output 1	40
16	Incremental encoder 4, track N-	16		41	Alarm acknowledgment output 2	41
17	Monitoring input 1	17		42	Alarm acknowledgment output 3	42
18	Monitoring input 2	18		43	Alarm acknowledgment output 4	43
19	Monitoring input 3	19		44	15 V encoder power supply	44
20	Monitoring input 4	20		45	Ground, encoder	45
21	Absolute encoder 3, data D+	21		46	Absolute encoder 4, data D+	46
22	Absolute encoder 3, data D-	22		47	Absolute encoder 4, data D-	47
23	Absolute encoder 3, clock C+	23		48	Absolute encoder 4, clock C+	48
24	Absolute encoder 3, clock C-	24		49	Absolute encoder 4, clock C-	49
25	Ground, encoder SSI	25		50	Ground, encoder SSI	50

Connector X3 with cable SC63

The assignment of the screw terminals at interface module SU13 corresponds to the connector assignment of X3.

Table 6-7 Pin assignment of X3

X3	Designation	SU13		X3	Designation	SU13
1	Digital output 1	1		26	Digital input 1	26
2	Digital output 2	2		27	Digital input 2	27
3	Digital output 3	3		28	Digital input 3	28

X3	Designation	SU13		X3	Designation	SU13
4	Digital output 4	4		29	Digital input 4	29
5	Digital output 5	5		30	Digital input 5	30
6	Digital output 6	6		31	Digital input 6	31
7	Digital output 7	7		32	Digital input 7	32
8	Digital output 8	8		33	Digital input 8	33
9	Ext. power supply +24V	9		34	-	34
10	External ground	10		35	External ground	35
11	Digital output 9	11		36	Digital input 9	36
12	Digital output 10	12		37	Digital input 10	37
13	Digital output 11	13		38	Digital input 11	38
14	Digital output 12	14		39	Digital input 12	39
15	Digital output 13	15		40	Digital input 13	40
16	Digital output 14	16		41	Digital input 14	41
17	Digital output 15	17		42	Digital input 15	42
18	Digital output 16	18		43	Digital input 16	43
19	Ext. power supply +24V	19		44	-	44
20	External ground	20		45	External ground	45
21	Absolute encoder 1, data D+	21		46	Absolute encoder 2, data D+	46
22	Absolute encoder 1, data D-	22		47	Absolute encoder 2, data D-	47
23	Absolute encoder 1, clock C+	23		48	Absolute encoder 2, clock C+	48
24	Absolute encoder 1, clock C-	24		49	Absolute encoder 2, clock C-	49
25	Ground, encoder SSI	25		50	Ground, encoder SSI	50

Connector X3 with cable SC62

Only specific signal types are available at the cable ends of SC62 which can only be used for the matching interface modules (refer to "Connection options [\(Page 102\)](#)").

Terminal assignment, interface modules

Table 6-8 Terminal assignment of the interface modules

Module type	Terminal (x=1...8)	Significance
SB10	x 5x	1:1 screw terminal connection <ul style="list-style-type: none"> • Signal • Reference potential (ground or P24)
SB60	x1 x2 x4	Digital inputs 115/120 V <ul style="list-style-type: none"> • Ground • Digital input 115 V • Digital input 120 V

Module type	Terminal (x=1...8)	Significance
SB61	x 1x 5x	Digital inputs 24/48 V <ul style="list-style-type: none"> Digital input 24 V Digital input 48 V Reference
SB70	x1 x2 x4	Digital outputs (relay) <ul style="list-style-type: none"> Root (center contact) NC contact NO contact
SB71	x 5x	Digital outputs (transistor) <ul style="list-style-type: none"> Signal Ground

Terminal assignment at cable SC62, end A

Table 6-9 Terminal assignments of the interface modules at connector X3, SC62 cable end A

X3	Designation	SU12	SB10	SB70	SB71
1	Digital output 1	1	1/51	11/12/14	1/51
2	Digital output 2	2	2/52	21/22/24	2/52
3	Digital output 3	3	3/53	31/32/34	3/53
4	Digital output 4	4	4/54	41/42/44	4/54
5	Digital output 5	5	5/55	51/52/54	5/55
6	Digital output 6	6	6/56	61/62/64	6/56
7	Digital output 7	7	7/57	71/72/74	7/57
8	Digital output 8	8	8/58	81/82/84	8/58
9	Ext. power supply +24V	9	1P	1P	1P
10	External ground	10	1M	1M	1M

Terminal assignment at cable SC62, end B

Table 6-10 Terminal assignments of the interface modules at connector X3, SC62 cable end B

X3	Designation	SU12	SB10	SB70	SB71
11	Digital output 9	1	1/51	11/12/14	1/51
12	Digital output 10	2	2/52	21/22/24	2/52
13	Digital output 11	3	3/53	31/32/34	3/53
14	Digital output 12	4	4/54	41/42/44	4/54
15	Digital output 13	5	5/55	51/52/54	5/55
16	Digital output 14	6	6/56	61/62/64	6/56
17	Digital output 15	7	7/57	71/72/74	7/57

X3	Designation	SU12	SB10	SB70	SB71
18	Digital output 16	8	8/58	81/82/84	8/58
19	Ext. power supply +24V	9	1P	1P	1P
20	External ground	10	1M	1M	1M

Terminal assignment at cable SC62, end C

Table 6-11 Terminal assignments of the interface modules at connector X3, SC62 cable end C

X3	Designation	SU12	SB10	SB60	SB61
26	Digital input 1	1	1/51	14/12/11	1/11/51
27	Digital input 2	2	2/52	24/22/21	2/12/52
28	Digital input 3	3	3/53	34/32/31	3/13/53
29	Digital input 4	4	4/54	44/42/41	4/14/54
30	Digital input 5	5	5/55	54/52/51	5/15/55
31	Digital input 6	6	6/56	64/62/61	6/16/56
32	Digital input 7	7	7/57	74/72/71	7/17/57
33	Digital input 8	8	8/58	84/82/81	8/18/58
34	-	9	1P	1P	1P
35	External ground	10	1M	1M	1M

Terminal assignment at cable SC62, end D

Table 6-12 Terminal assignments of the interface modules at connector X3, SC62 cable end D

X3	Designation	SU12	SB10	SB60	SB61
36	Digital input 9	1	1/51	14/12/11	1/11/51
37	Digital input 10	2	2/52	24/22/21	2/12/52
38	Digital input 11	3	3/53	34/32/31	3/13/53
39	Digital input 12	4	4/54	44/42/41	4/14/54
40	Digital input 13	5	5/55	54/52/51	5/15/55
41	Digital input 14	6	6/56	64/62/61	6/16/56
42	Digital input 15	7	7/57	74/72/71	7/17/57
43	Digital input 16	8	8/58	84/82/81	8/18/58
44	-	9	1P	1P	1P
45	External ground	10	1M	1M	1M

Terminal assignment at cable SC62, end E

Table 6-13 Terminal assignments of the interface module at connector X3, SC62 cable end E

X3	Designation	SU12
21	Absolute encoder 1, data D+	1
22	Absolute encoder 1, data D-	2
23	Absolute encoder 1, clock C+	3
24	Absolute encoder 1, clock C-	4
25	Ground, encoder SSI	5
46	Absolute encoder 2, data D+	6
47	Absolute encoder 2, data D-	7
48	Absolute encoder 2, clock C+	8
49	Absolute encoder 2, clock C-	9
50	Ground, encoder SSI	10

6.1.9 Technical specifications/performance features

Article number

SM500 signal module	6DD1640-0AH0
---------------------	--------------

Analog outputs

Number	8
Version	Output with associated ground
Electrical isolation	No
Output voltage range	-10 V to +10 V
Output current	± 10 mA
Resolution	12 bits
Typical conversion time per channel	4 µs
Tolerance <ul style="list-style-type: none"> Differential linearity error, max. Gain error, max. Offset error, max. 	± 1 LSB (monotony guaranteed) ± 0.3% ± 24 LSB
Slew rate	approx. 3.5 V/µs
Voltage output <ul style="list-style-type: none"> Short-circuit protection Short-circuit current 	Yes (to ground) Approx. 100 mA

Analog inputs

Number	8
Version	Differential inputs
Electrical isolation	No
Input voltage range	-10 V to +10 V
Resolution	12 bits
Conversion time per channel, max	approx. 20 μ s
Tolerance <ul style="list-style-type: none"> • Differential linearity error, max. • Gain error, max. • Offset error, max. 	<ul style="list-style-type: none"> ± 1 LSB (No missing code) $\pm 0.3\%$ ± 5 LSB
Input resistance	20 k Ω
Input filter	34 kHz
Reverse polarity protection	Yes, as differential inputs are used

Integrating analog inputs

Number	4
Version	Differential inputs
Electrical isolation	No
Input voltage range	-10 V to +10 V
Resolution	Depending on the integration time, e.g. 15 bits for a 4 ms integration time.
Integration time per channel, max	Configurable
Tolerance <ul style="list-style-type: none"> Integral linearity error, max. Gain error, max. Typical offset error 	<ul style="list-style-type: none"> 0.05% 1% 2 LSB (software adjustment)
Input resistance	470 k Ω
Input filter	2 kHz
Reverse polarity protection	Yes, as differential inputs are used

Digital outputs

Number	16
Electrical isolation	No
External power supply <ul style="list-style-type: none"> Rated voltage Perm. range short-term Current consumption, max., no load 	24 V 20.4 V to 28.8 V 35 V (for max. 0.5 s) 40 mA
Output voltage range <ul style="list-style-type: none"> With 0 signal, max. With 1 signal, min. 	3 V Ext. supply voltage – 2.5 V
Output current <ul style="list-style-type: none"> With 0 signal, min. at 1 signal <ul style="list-style-type: none"> Rated value Valid range, max. 	-20 µA 50 mA 100 mA
Delay time	100 µsec
Switching frequency of outputs With resistance load, max.	6 kHz
Short-circuit protection to <ul style="list-style-type: none"> Ground External power supply 	yes No
Short-circuit current, max.	250 mA
Total current of outputs (up to 60 °C)	16 x 50 mA
Limiting of inductive cut-off voltages	Ext. supply voltage +1 V

Digital inputs

Number	16
Electrical isolation	No
Input voltage <ul style="list-style-type: none"> Rated voltage For 0 signal For 1 signal 	24 V -1 V to + 6 V +13.5 V to +33 V
Input current <ul style="list-style-type: none"> For 0 signal, normally For 1 signal, normally 	0 mA 3 mA
Delay time per channel, max.	100 µsec

Incremental encoder

Encoder types that conform to technical specifications may be connected to the incremental encoder inputs.

Number	4	
Connectable types	Incremental encoders with 90° track phase offset	Incremental encoders with separate up/down tracks
Version	Differential inputs, selectable 15 V (HTL) or 5 V (TTL) encoder signal	
Track signals	Tracks A, B with/without zero pulse	Up/down tracks
Phase difference of track signals, min.	200 ns	
Pulse frequency, max.	1 MHz	2.5 MHz
Interference pulse suppression	Configurable	
Electrical isolation	No	
Input voltage		
<ul style="list-style-type: none"> • 15 V – encoder: <ul style="list-style-type: none"> – Valid range – at 0 signal – at 1 signal • 5 V – encoder <ul style="list-style-type: none"> – Valid range – at 0 signal – at 1 signal 	-30 V to +30 V -30 V to +4 V +8 V to +30 V -7 V to +7 V -7 V to -0.7 V +1.5 V to +7 V	
Input current		
<ul style="list-style-type: none"> • 15 V – encoder (typ., abs.) • 5 V – encoder (typ., abs.) 	5 mA 1.5 mA	
Monitoring output	Not available	
Monitoring input	Specification as for digital inputs	
Interrupt reset output		
<ul style="list-style-type: none"> • Short-circuit protection to <ul style="list-style-type: none"> – Ground – External power supply • Short-circuit current, max. 	yes No 20 mA	
Interrupt input		
Input voltage		
<ul style="list-style-type: none"> • Valid range • 0 signal, max. • 1 signal, min. 	0 V to 5 V < 0.5 V > 2.0 V	
Input current		
<ul style="list-style-type: none"> • 0 signal, min. • 1 signal, min. 	-2.8 mA -1.6 mA	

Absolute encoders

Number	4
Version	Differential inputs, RS485 signal level
Connectable types	
Log files	SSI, EnDat
Data formats	Gray code, binary
Data direction <ul style="list-style-type: none"> • Unidirectional • Bidirectional 	SSI: Unidirectional EnDat : Bidirectional
Data bits	SSI: 25 + parity EnDat : variable
Pulse frequency, max.	2 MHz
Electrical isolation	No
Input voltage	RS485 signal level

Sensor supply voltage

Version	
Typical output voltage	13.5 V
Output current, max.	150 mA (short circuit-proof, short-circuit current approx. 250 mA)

Voltage, currents

Rated voltages at 25 °C	Typical current consumption
+5 V	1 A
+3,3 V	50 mA
+12 V	300 mA
-12 V	300 mA

Power losses/fan

Typical power losses	12.5 W
Fan required	yes

Dimensions

Number of slots required in the rack	1
Dimensions W x H x D [mm]	20 x 233 x 160
Weight, approx.	0.4 kg

6.2 SM500 DI/DQ signal module

6.2.1 Areas of application

The SM500 DI/DQ signal module provides digital inputs and outputs.

Use cases include:

- Connection of digital actuators and sensors
- Status display by means of integrated LEDs

6.2.2 Control and display elements

LED displays

The SM500 DI/DQ signal module is equipped with 8 LEDs. H1 and H2 provide information about the current module state.

Table 6-14 LED displays of the SM500 DI/DQ signal module

LED designation (color)	Function
H1 (green) and H2 (red)	Module status display
H3 (green) and H4 (green)	Can be controlled by means of function block BIQ8 (digital output).
H5 (green) and H6 (green)	
H7 (green) and H8 (green)	

Front panel

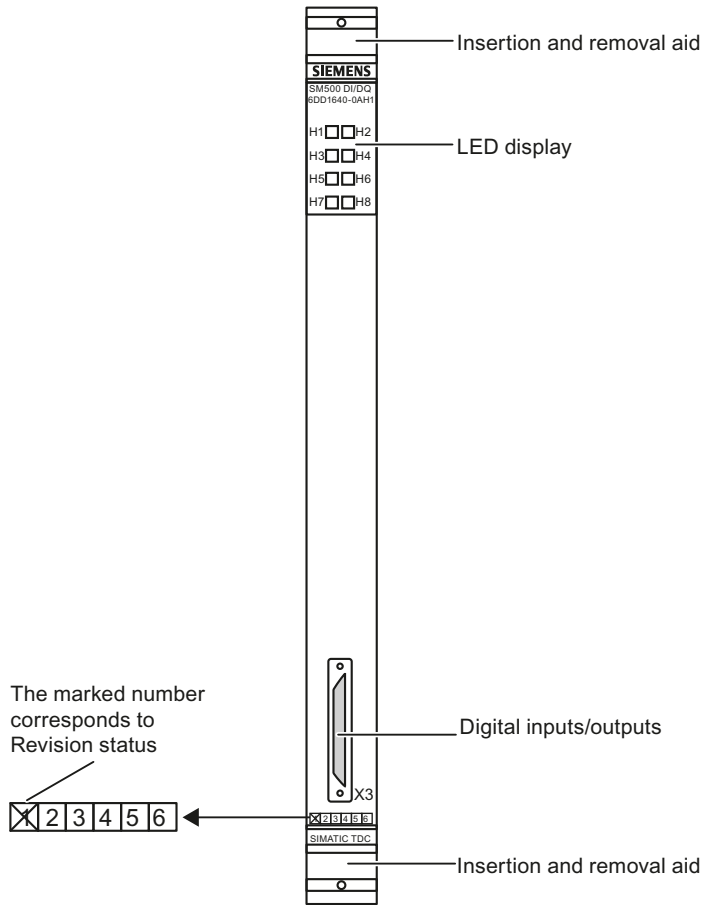

Figure 6-3 Front panel of SM500 DI/DQ

6.2.3 Status and fault displays

Status displays for SM500 DI/DQ

Table 6-15 Status displays for the SM500 DI/DQ signal module

LED display		Module status
H1	H2	
Off	Off	During voltage run-up
Off	On	FPGAs are configured, module is not initialized
On	Off	Module is initialized and operating error-free
On	On	After 3.3 V voltage failure <ul style="list-style-type: none"> • Hardware failure => Power-down the rack and replace the SM500

6.2.4 Application notes and immunity to interference

- Fan operation is required
- Interference-proof operation is only possible if the SM500 DI/DQ is firmly attached to the rack. Insert the module and then bolt it onto the rack accordingly (two screw heads, see Control and display elements (Page 115)).
- The module may not be inserted or removed while the rack is on live voltage.

NOTE

For more information on fan operation, refer to chapter "Rack (Page 43)".

For more information on EMC and environmental conditions, refer to chapter "General technical specifications (Page 41)".

6.2.5 Connection options

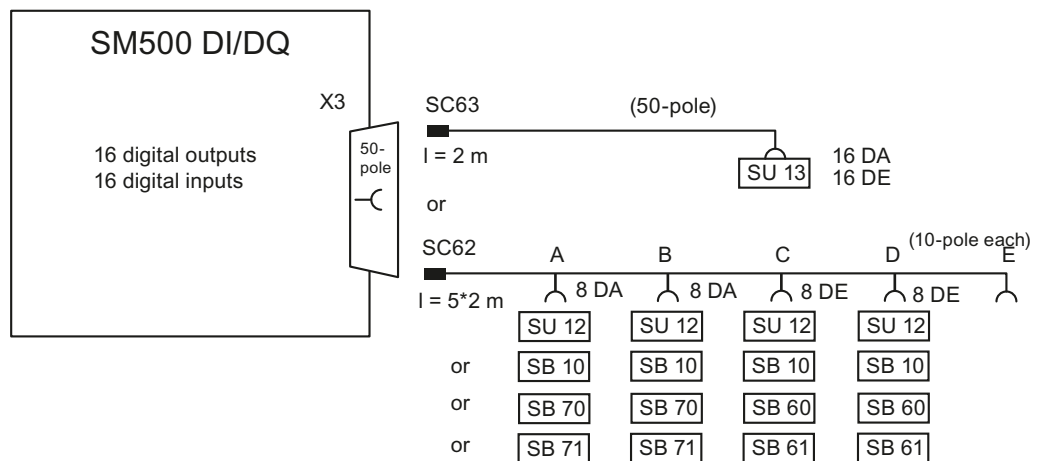

Figure 6-4 Connection options for the SM500 DI/DQ

6.2.6 Additional components

Table 6-16 Cables and interface modules for the SM500 DI/DQ signal module

Component	Designation	Article number
Cable for SM500 DI/DQ (50-pole/5*10-pole)	SC62	6DD1684-0GC0
Cable for digital inputs (50-pole/50-pole)	SC63	6DD1684-0GD0
Interface module Direct wiring (1:1 wiring), 10 screw terminals, no signal conversion	SU12	6DD1681-0AJ1
Interface module Direct wiring (1:1 wiring), 50 screw terminals, no signal conversion	SU13	6DD1681-0GK0

Component	Designation	Article number
Interface module Direct wiring (1:1 wiring), 8 digital I/O, LED, no signal conversion	SB10	6DD1681-0AE2
Interface module 8 digital inputs, conversion, 120 V to 24 V (module signal level), LED, electrical isolation	SB60	6DD1681-0AF4
Interface module 8 digital inputs, conversion 48 V to 24 V, LED, electrical isolation	SB61	6DD1681-0EB3
Interface module 8 digital outputs, conversion, 24 V to 120 V (changeover relay), LED, electrical isolation	SB70	6DD1681-0AG2
Interface module 8 digital outputs, conversion 25 V to 48 V (transistor)	SB71	6DD1681-0DH1

6.2.7 Pin assignments

Connector X3 with cable SC63

The assignment of the screw terminals at interface module SU13 corresponds to the connector assignment of X3.

Table 6-17 Pin assignment of X3

X3	Designation	SU13	X3	Designation	SU13
1	Digital output 1	1	26	Digital input 1	26
2	Digital output 2	2	27	Digital input 2	27
3	Digital output 3	3	28	Digital input 3	28
4	Digital output 4	4	29	Digital input 4	29
5	Digital output 5	5	30	Digital input 5	30
6	Digital output 6	6	31	Digital input 6	31
7	Digital output 7	7	32	Digital input 7	32
8	Digital output 8	8	33	Digital input 8	33
9	Ext. power supply +24V	9	34	-	34
10	External ground	10	35	External ground	35
11	Digital output 9	11	36	Digital input 9	36
12	Digital output 10	12	37	Digital input 10	37
13	Digital output 11	13	38	Digital input 11	38
14	Digital output 12	14	39	Digital input 12	39
15	Digital output 13	15	40	Digital input 13	40
16	Digital output 14	16	41	Digital input 14	41
17	Digital output 15	17	42	Digital input 15	42

X3	Designation	SU13		X3	Designation	SU13
18	Digital output 16	18		43	Digital input 16	43
19	Ext. power supply +24V	19		44	-	44
20	External ground	20		45	External ground	45

Connector X3 with cable SC62

Only specific signal types are available at the cable ends of SC62 which can only be used for the matching interface modules (refer to "Connection options [\(Page 117\)](#)").

Terminal assignment, interface modules

Table 6-18 Terminal assignment of the interface modules

Module type	Terminal (x=1...8)	Significance
SB10	x 5x	1:1 screw terminal connection <ul style="list-style-type: none"> • Signal • Reference potential (ground or P24)
SB60	x1 x2 x4	Digital inputs 115/120 V <ul style="list-style-type: none"> • Ground • Digital input 115 V • Digital input 120 V
SB61	x 1x 5x	Digital inputs 24/48 V <ul style="list-style-type: none"> • Digital input 24 V • Digital input 48 V • Reference
SB70	x1 x2 x4	Digital outputs (relay) <ul style="list-style-type: none"> • Root (center contact) • NC contact • NO contact
SB71	x 5x	Digital outputs (transistor) <ul style="list-style-type: none"> • Signal • Ground

Terminal assignment at cable SC62, end A

Table 6-19 Terminal assignments of the interface modules at connector X3, SC62 cable end A

X3	Designation	SU12	SB10	SB70	SB71
1	Digital output 1	1	1/51	11/12/14	1/51
2	Digital output 2	2	2/52	21/22/24	2/52
3	Digital output 3	3	3/53	31/32/34	3/53
4	Digital output 4	4	4/54	41/42/44	4/54
5	Digital output 5	5	5/55	51/52/54	5/55
6	Digital output 6	6	6/56	61/62/64	6/56
7	Digital output 7	7	7/57	71/72/74	7/57
8	Digital output 8	8	8/58	81/82/84	8/58
9	Ext. power supply +24V	9	1P	1P	1P
10	External ground	10	1M	1M	1M

Terminal assignment at cable SC62, end B

Table 6-20 Terminal assignments of the interface modules at connector X3, SC62 cable end B

X3	Designation	SU12	SB10	SB70	SB71
11	Digital output 9	1	1/51	11/12/14	1/51
12	Digital output 10	2	2/52	21/22/24	2/52
13	Digital output 11	3	3/53	31/32/34	3/53
14	Digital output 12	4	4/54	41/42/44	4/54
15	Digital output 13	5	5/55	51/52/54	5/55
16	Digital output 14	6	6/56	61/62/64	6/56
17	Digital output 15	7	7/57	71/72/74	7/57
18	Digital output 16	8	8/58	81/82/84	8/58
19	Ext. power supply +24V	9	1P	1P	1P
20	External ground	10	1M	1M	1M

Terminal assignment at cable SC62, end C

Table 6-21 Terminal assignments of the interface modules at connector X3, SC62 cable end C

X3	Designation	SU12	SB10	SB60	SB61
26	Digital input 1	1	1/51	14/12/11	1/11/51
27	Digital input 2	2	2/52	24/22/21	2/12/52
28	Digital input 3	3	3/53	34/32/31	3/13/53
29	Digital input 4	4	4/54	44/42/41	4/14/54
30	Digital input 5	5	5/55	54/52/51	5/15/55

X3	Designation	SU12	SB10	SB60	SB61
31	Digital input 6	6	6/56	64/62/61	6/16/56
32	Digital input 7	7	7/57	74/72/71	7/17/57
33	Digital input 8	8	8/58	84/82/81	8/18/58
34	-	9	1P	1P	1P
35	External ground	10	1M	1M	1M

Terminal assignment at cable SC62, end D

Table 6-22 Terminal assignments of the interface modules at connector X3, SC62 cable end D

X3	Designation	SU12	SB10	SB60	SB61
36	Digital input 9	1	1/51	14/12/11	1/11/51
37	Digital input 10	2	2/52	24/22/21	2/12/52
38	Digital input 11	3	3/53	34/32/31	3/13/53
39	Digital input 12	4	4/54	44/42/41	4/14/54
40	Digital input 13	5	5/55	54/52/51	5/15/55
41	Digital input 14	6	6/56	64/62/61	6/16/56
42	Digital input 15	7	7/57	74/72/71	7/17/57
43	Digital input 16	8	8/58	84/82/81	8/18/58
44	-	9	1P	1P	1P
45	External ground	10	1M	1M	1M

Terminal assignment at cable SC62, end E

The signals at cable end E are not connected on the module.

6.2.8 Technical specifications/performance features

Article number

SM500 DI/DQ signal module	6DD1640-0AH1
---------------------------	--------------

Digital outputs

Number	16
Electrical isolation	No
External power supply <ul style="list-style-type: none"> Rated voltage Perm. range short-term Current consumption, max., no load 	24 V 20.4 V to 28.8 V 35 V (for max. 0.5 s) 40 mA
Output voltage range <ul style="list-style-type: none"> With 0 signal, max. With 1 signal, min. 	3 V Ext. supply voltage – 2.5 V
Output current <ul style="list-style-type: none"> With 0 signal, min. at 1 signal <ul style="list-style-type: none"> Rated value Valid range, max. 	-20 µA 50 mA 100 mA
Delay time	100 µsec
Switching frequency of outputs With resistance load, max.	6 kHz
Short-circuit protection to <ul style="list-style-type: none"> Ground External power supply 	yes No
Short-circuit current, max.	250 mA
Total current of outputs (up to 60 °C)	16 x 50 mA
Limiting of inductive cut-off voltages	Ext. supply voltage +1 V

Digital inputs

Number	16
Electrical isolation	No
Input voltage <ul style="list-style-type: none"> • Rated voltage • For 0 signal • For 1 signal 	24 V -1 V to + 6 V +13.5 V to +33 V
Input current <ul style="list-style-type: none"> • For 0 signal, normally • For 1 signal, normally 	0 mA 3 mA
Delay time per channel, max.	100 µsec

Voltage, currents

Rated voltages at 25 °C	Typical current consumption
+5 V	0.4 A
+3,3 V	50 mA
+12 V	—
-12 V	—

Power losses/fan

Typical power losses	3 watts
Fan required	yes

Dimensions

Number of slots required in the rack	1
Dimensions W x H x D [mm]	20 x 233 x 160
Weight, approx.	0.3 kg

Communication modules

7.1 CP50M1 communication module

7.1.1 Areas of application

CP50M1 is a communication module with communication memory function and two PROFIBUS DP interfaces (MPI interface only on X1).

Use cases include:

- Interfacing with distributed I/O devices and/or drives (master and/or slave function)
- Central commissioning of all CPU modules in the rack (MPI nodes)
- Buffer memory for data exchange between CPU modules
- Function for routing to other CP modules
- Connection of SIMATIC visualization components, e.g.: WinCC, or OP/TD

Replacing a CP50M0 with a CP50M1

NOTE

Replacement parts compatibility

The CP50M1 is not compatible with CP50M0 as a replacement part.

If a CP50M0 is replaced by a CP50M1, it must be re-configured in HW Config.

	CP50M0	CP50M1
Article number	6DD1661-0AD0	6DD1661-0AD1
PROFIBUS DP interface (X1 / X2)	2 (X1 + X2 optionally DP or MPI)	2 (X1 optionally DP or MPI)
MPI interface	2	1
Parameter assignment and diagnostics interface	yes	yes
Function for routing to other CP modules	No	yes
Communication memory	----	SDRAM, 1 MB
Buffer memory module	DRAM, 8 MB	SDRAM, 8 MB
Rated voltage	Current consumption	Current consumption
+5 V	1 A	1 A
+3,3 V	---	100 mA
+12 V	---	20 mA
-12 V	---	10 mA
Ext. battery (min. 2.2 V, typ. 3.0 V)	350 nA	---

Typical power losses	5 W	5,5 W
Fan required	yes	No
Slots required	1	1
Dimensions W x H x D (mm)	20 x 233 x 160	20 x 233 x 160
Weight	0,34 kg	0,6 kg

7.1.2 Control and display elements

LED displays

LEDs H1, H2, H7 and H8 indicate the operating state of communication module CP50M1.
 LEDs H3 to H6 provide information about the current operating state of the two PROFIBUS DP channels.

Front panel

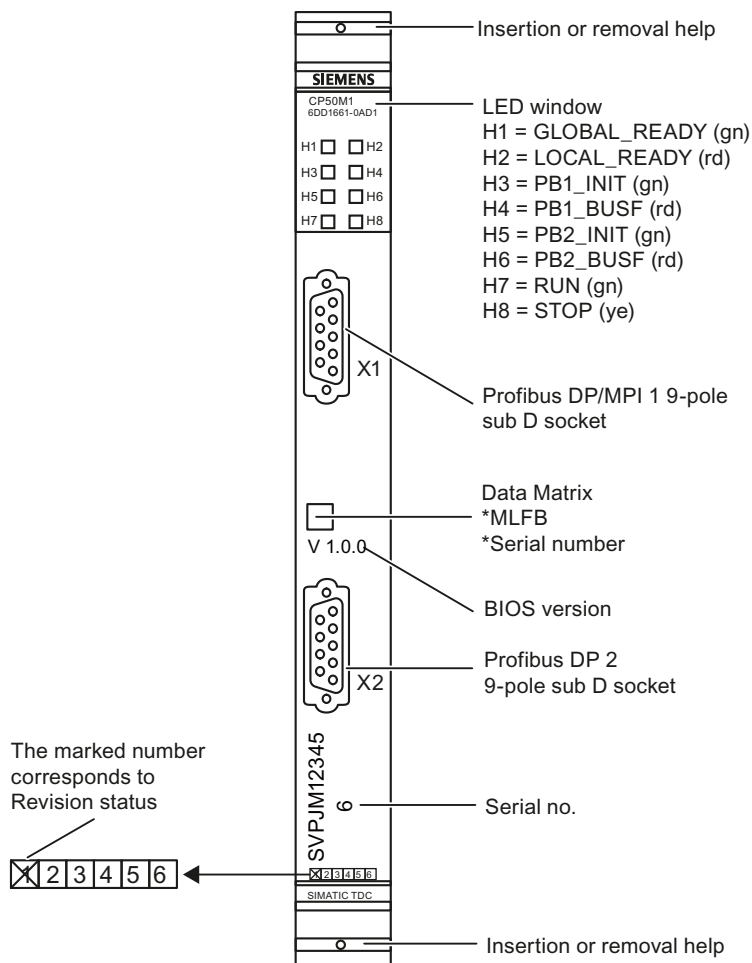

Figure 7-1 Front panel of CP50M1

7.1.3 Status and fault displays

Status displays for operation of the CP50M1 module

Table 7-1 Operating state displays for CP50M1 (LED H1 and H2)

Display		Operation state
H1 (green)	H2 (red)	
Off	Off	CP50M1 is switched off or not parameterized
Off	On	CP50M1 is ready but not yet initialized
On	Off	CP50M1 has been initialized
On	On	Power failure on CP50M1

Table 7-2 Operating state displays for CP50M1 (LED H7 and H8)

Display		Operation state
H7 (green)	H8 (yellow)	
Off	Off	Module is switched off (off-current state)
Off	On	STOP operating state Initialization error, no valid configuration found
Flashing	Off	CP50M1 startup
On	Off	RUN operating state Startup completed, CP50M1 is in normal operation
Flashing	Flashing	Module is defective

Status displays for PROFIBUS DP interfaces

Table 7-3 Operating state displays for CP50M1 (LED H3 to H6)

LED	Display	Operation state
H3 (green)	On	CP50M1, PB-DP1 is initialized and ready
H4 (red)	On	CP50M1, PB-DP1 bus error
	Flashing	CP50M1, one or several slaves connected to the PB-DP1 interface are not responding Module is defective
H5 (green)	On	CP50M1, PB-DP2 is initialized and ready
H6 (red)	On	CP50M1, PB-DP2 bus error
	Flashing	CP50M1, one or several slaves connected to the PB-DP2 interface are not responding Module is defective

7.1.4 Application notes and immunity to interference

- Interference-free operation is only possible if the CP50M1 is firmly attached to the subrack. Insert the module and then bolt it onto the rack accordingly (two screw heads, "Control and display elements (Page 125)").
- The module may not be inserted or removed while the rack is on live voltage.
- The factory setting of switch S1 may not be changed (refer to "Connection options (Page 127)").

NOTE

For more information on fan operation, refer to chapter "Rack (Page 43)"!

For more information on EMC and environmental conditions, refer to chapter "General technical specifications (Page 41)"!

7.1.5 Connection options

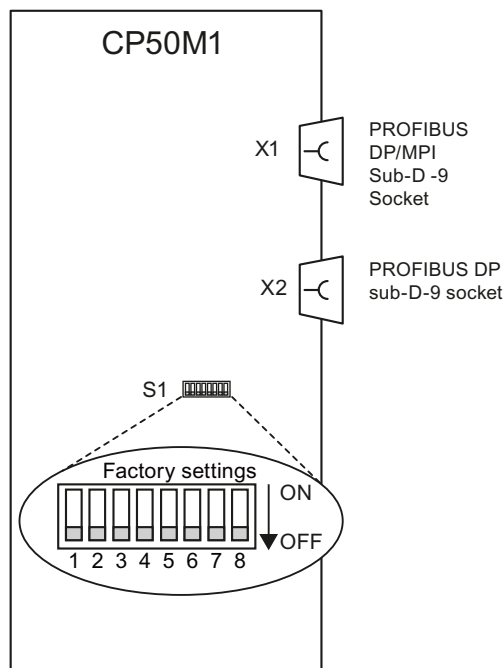

Figure 7-2 Connection options of CP50M1

7.1.6 Additional components

Examples for PROFIBUS RS485 bus connector

- 6ES7972-0BA12-0XA0 (90°; without PG socket)
- 6ES7972-0BA12-0XA0 (90°; without PG socket)
- 6ES7972-0BA42-0XA0 (35°; without PG socket)
- 6ES7972-0BB42-0XA0 (35°; without PG socket)
- 6ES7972-0BA30-0XA0 (30°; without PG socket)

Examples for fabricated cables (RS485)

- 6XV1830-1CH15 (1.5 m)
- 6XV1830-1CH30 (3 m)
- 6XV1830-2AH30 (3 m; PG)
- 6XV1830-2AH50 (5 m; PG)
- 6XV1830-2AN10 (10 m; PG)

NOTE

You can find more information in the SIMATIC NET Catalog IK PI or in the SIMATIC S7 Catalog.

7.1.7 Pin assignments

PROFIBUS DP/MPI interface X1 and X2

The following connections are assigned to the 9-pin sub-D receptacle:

- PROFIBUS interface, RS 485 format and electrical isolation
- 5 V power supply for Optical Link Modules (OLM) with electrical isolation

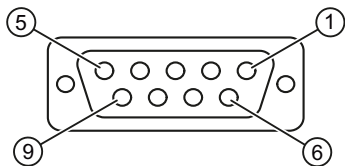

Table 7-4 Pin assignment of X1 and X2

Pin	Designation	Explanation
1	n.c.	n.c.
2	PB1/2_M24V	Ground, non-isolated
3	PB1/2_RS458_B	Line B
4	PB1/2_RTSAS	RTS from AS

Pin	Designation	Explanation
5	1/2MEXT	Ground P5, electrically isolated (to supply OLMs)
6	1/2P5EXT	P5 electrically isolated (to OLM supply) (5 V DC/90 mA)
7	PB1/2_P24MPI	P24, non-isolated (24 V DC/150 mA)
8	PB1/2_RS458_A	Line A
9	PB1/2_RTSPG	RTS from programming device (n.c.)
Enclosure	Shield	

7.1.8 Technical specifications/performance features

Article number

CP50M1 communication module	6DD1661-0AD1
-----------------------------	--------------

Memory

Communication memory	SRAM, 1 MB
Buffer memory module	SDRAM, 8 MB, 1 MB of which for buffer memory coupling (e.g. CRV, CTV blocks) You can find additional information in the System and Communication Configuration D7-SYS system manual, in the section Buffer memory coupling.
Note: Of several CP50M1 that are inserted in a rack, only the CP at the extreme left has the communication memory function. All others may only be configured as pure communication modules (2 PROFIBUS DP/MPI interfaces).	
VMEbus configuration memory	NOR Flash, 512 KB

Interfaces

2 PROFIBUS interfaces (X1 and X2) – X1 can be configured as DP or MPI

NOTE

The two interfaces X1 and X2 are to be considered as one unit when assigning the DP address (I/O addresses in the shared address range may be assigned only once, i.e. if the entire I/O address range is used for one interface, the second interface can no longer be used).

PROFIBUS DP interfaces <ul style="list-style-type: none"> • Master or slave interface for PROFIBUS DP, including "Shared Input", SYNC, and FREEZE functions • Multimastering supported • Transmission rates • Frame length per slave • Status display via LEDs 	RS 485 format <ul style="list-style-type: none"> • 9.6 kbps to 12 Mbps • max. 244 bytes • See Status and fault displays (Page 126)
MPI interfaces <ul style="list-style-type: none"> • Status display via LEDs • PG/OP services can be used 	<ul style="list-style-type: none"> • See Status and fault displays (Page 126) • E.g. coupling with the configuration station (CFC in test mode)
Power supply to Optical Link Modules (OLM) with electrical isolation	See Pin assignments (Page 128)

Communication

Communication functions	<ul style="list-style-type: none"> • PROFIBUS DP coupling • MPI coupling • Buffer memory coupling
-------------------------	--

Voltage, currents

Rated voltages at 25 °C	Typical current consumption
+5 V DC (from rack)	1 A
External battery (min. 2.2 V, typically 3.0 V)	350 nA

Power losses/fan

Typical power losses	5 W
Fan required	Yes, external fan

Dimensions

Number of slots required in the rack	1
Dimensions W x H x D [mm]	20 x 233 x 160
Weight	0.4 kg

7.2 CP51M1 communication module

7.2.1 Areas of application

CP51M1 is an Industrial Ethernet interface with buffer memory function. It can be used for the following applications:

- Exchange of process data with other CP51M1 and SIMATIC Industrial Ethernet modules (e.g. CP443-1)
- Visualization of process data in WinCC
- Visualization of messages in WinCC
- Exchange of process data with third-party systems (e.g. process computers)
- Central commissioning and diagnostics of all CPU modules in the rack
- Buffer memory for data exchange between CPU modules
- Time synchronization for uniform system time

7.2.2 Control and display elements

LED displays

LEDs H1, H2, H7 and H8 indicate the operating state of communication module CP51M1.

LEDs H3 to H6 provide information about the current network traffic.

Front panel

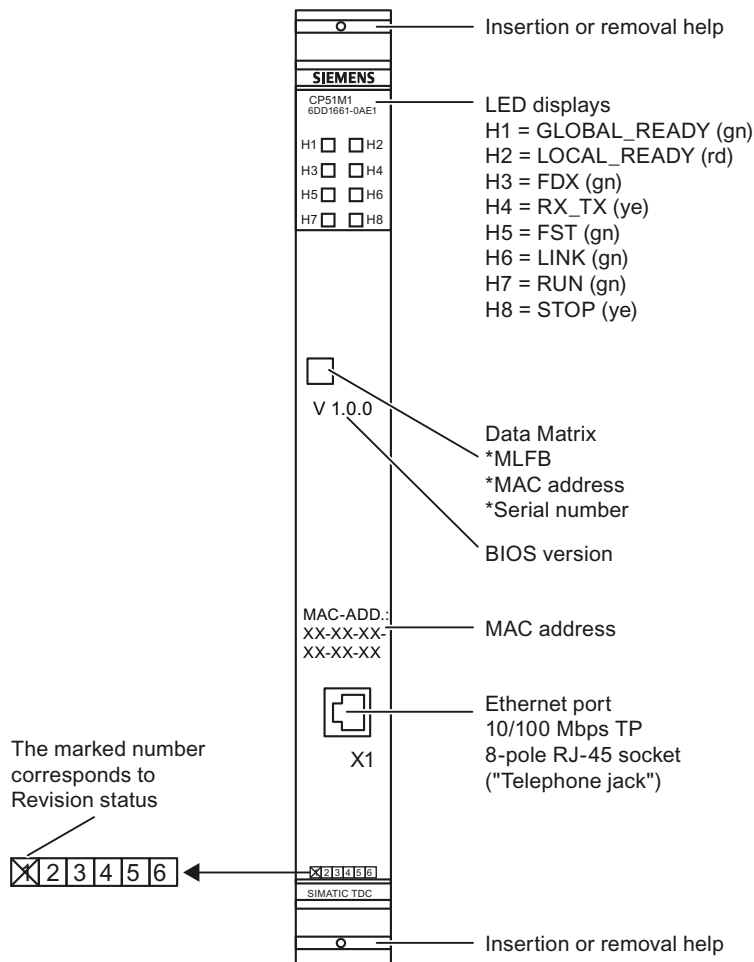

Figure 7-3 Front panel of CP51M1

7.2.3 Status and fault displays

Status displays for module operation

Table 7-5 Operating state displays for CP51M1 (LED H1 and H2)

Display		Operation state
H1 (green)	H2 (red)	
Off	Off	CP51M1 is switched off or not parameterized
Off	On	CP51M1 is ready but not yet initialized
On	Off	CP51M1 is initialized
On	On	Power failure on CP51M1

Table 7-6 Operating state displays for CP51M1 (LED H7 and H8)

Display		Operation state
H7 (green)	H8 (yellow)	
Off	Off	Module is switched off (off-current state)
Off	On	STOP operating state Initialization error, no valid configuration found
Flashing	Off	CP51M1 startup
On	Off	RUN operating state Startup completed, CP51M1 is in normal operation
Flashing	Flashing	Module is defective

Status displays for network operation

Table 7-7 Operating state displays for CP51M1 (LED H3 to H6)

LED	Display	Operation state
H3 (green)	On	CP51M1 has at least one full duplex connection
	Flashing	Module is defective
H4 (yellow)	On	Data traffic in transmit and/or receive direction on Ethernet
H5 (green)	On	CP51M1 is communicating via Fast Ethernet (100 Mbps)
	Flashing	CP51M1 is in the "auto-sensing phase"
H6 (green)	On	CP51M1 is connected (link) to an Ethernet compatible device (hub, switch, PC)

7.2.4 Application notes and immunity to interference

- Interference-proof operation is only possible if CP51M1 is firmly attached to the rack. Insert the module and then bolt it onto the rack accordingly (two screw heads, see "Control and display elements (Page 132)").
- The module may not be inserted or removed while the rack is on live voltage.
- The factory setting of switch S1 may not be changed (refer to "Connection options (Page 134)").

NOTE

For more information on fan operation, refer to chapter "Rack (Page 43)"!

For more information on EMC and environmental conditions, refer to chapter "General technical specifications (Page 41)"!

7.2.5 Connection options

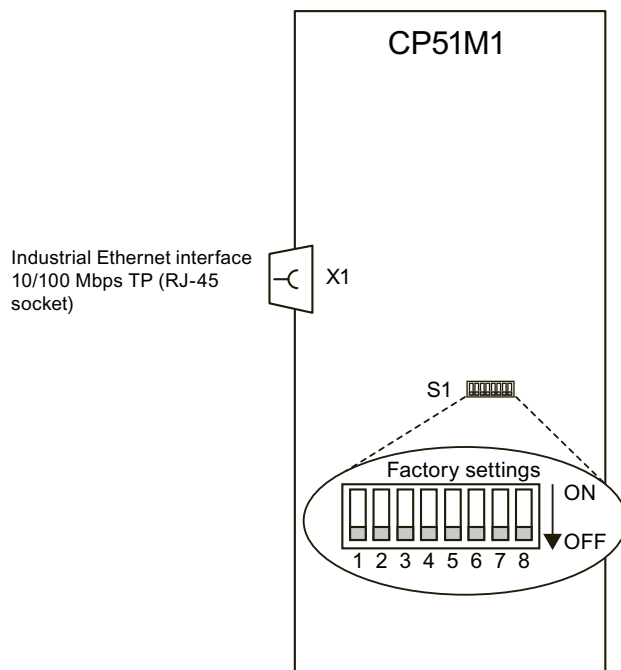

Figure 7-4 Connection options of CP51M1

7.2.6 Additional components

Connecting cables

Designation	Article number
SIMATIC NET, Industrial Ethernet TP XP CORD RJ45/RJ45, dressed with 2 x RJ45 connectors, length ...	6XV1870-3R...

You can find more information in the SIMATIC NET Catalog IK PI or in the Siemens Industry Mall (<https://mall.industry.siemens.com>).

For more information on networks and their cabling, refer to the following documentation:

- Industrial Ethernet/PROFINET
Passive Network Components system manual
(<http://support.automation.siemens.com/WW/view/de/84922825/0/en>)
- Industrial Ethernet/PROFINET
Industrial Ethernet system manual
(<http://support.automation.siemens.com/WW/view/de/27069465/0/en>)

7.2.7 Pin assignments

Industrial Ethernet interface X1, 10/100 Mbps TP(RJ-45 jack)

Table 7-8 Pin assignment of X1 (RJ-45 jack)

PIN	Designation
1	TX+
2	TX -
3	RX+
4	75 ohm termination
5	75 ohm termination
6	RX-
7	75 ohm termination
8	75 ohm termination
Enclosure	Shield

NOTE

This interface does not allow crossover of transmitting and receiving cables (no Auto-MDIX). If you wish to connect two CP51M1 directly with one another, you need to use a Ethernet crossover cable (Page 135).

7.2.8 Technical specifications/performance features

Article number

CP51M1 communication module	6DD1661-0AE1
-----------------------------	--------------

Memory

Communication memory	SRAM, 512 KB
Buffer memory module	SDRAM, 8 MB, 1 MB of which for buffer memory coupling (e.g. CRV, CTV blocks) You can find additional information in the System and Communication Configuration D7-SYS system manual, in the section Buffer memory coupling.

NOTE

Of several CP51M1 that are inserted in a rack, only the CP51M1 at the far left has the communication memory function.

Network interface

Industrial Ethernet (10/100BTX) X1	
Log files	TCP/IP, UDP and ISO over TCP/IP (RFC1006) for S7 Communication (programming device / OS)
TCP/IP frame lengths	32 KB
UDP frame lengths	send 2064 bytes receive 2048 bytes
Transmission modes	Refresh, Handshake, Multiple and Select
Autosensing	For 10 Mbit or 100 Mbit networks
Autonegotiation	For 10 Mbit or 100 Mbit networks and full duplex / half duplex
Default router	Can be set
Dielectric strength to IEEE 802.3	1500 V _{ac}

Voltage, currents

Rated voltages at 25 °C	Typical current consumption
+5 V DC (from rack)	1.044 A
External battery (min. 2.2 V, typically 3.0 V)	350 nA

Power losses/fan

Typical power losses	5.22 W
Fan required	Yes, external fan

Dimensions

Number of slots required in the rack	1
Dimensions W x H x D [mm]	20 x 233 x 160
Weight	0.3 kg

7.3 GDM memory module CP52M0

7.3.1 Areas of application

GlobalDataMemory

GlobalDataMemory (GDM) facilitates data exchange between all CPU modules in all racks of the system.

Since central memory supports the synchronous coupling of up to 44 racks, it is possible to operate up to 836 CPU modules in a maximum system configuration.

A separate rack is used for GDM. The **CP52M0 memory module (slot 1)** and an appropriate number of CP52IO interface modules (slots 2-12) are accommodated in the UR5213 or UR6021 racks with 21 slots.

Each rack that is coupled with GDM must be equipped with a CP52A0 access module. These racks are interconnected with GDM by means of fiber-optic cables in a star topology.

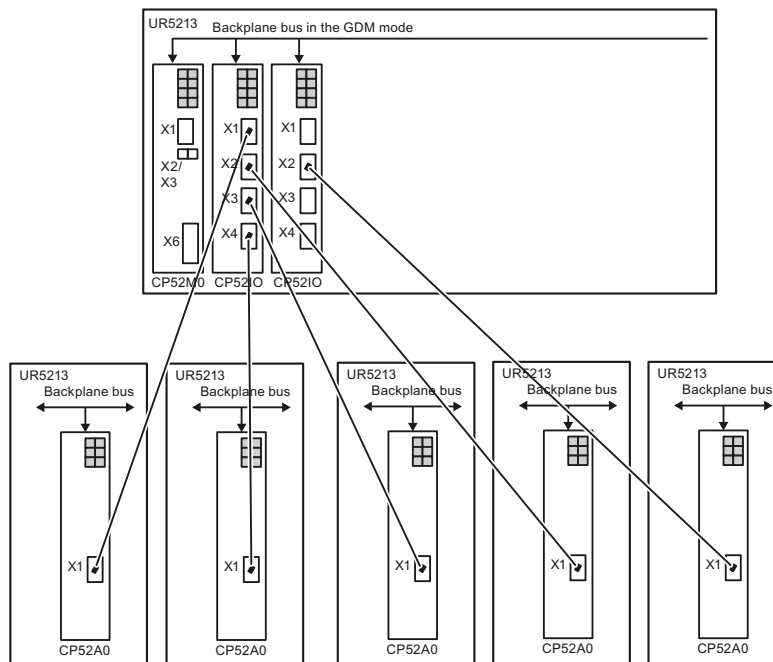

Figure 7-5 Example of a GDM system with 5 racks that are coupled with FOCs

CP52M0 function

The CP52M0 GDM memory module provides 2 MB of central memory for the GlobalDataMemory system. This memory module handles the entire data traffic between the processors in the coupled racks.

Data is exchanged between the GDM interface modules CP52IO and the CP52M0 via the backplane bus.

CP52M0 reads the fault and diagnostics registers from all fiber-optic interfaces of the CP52IOs inserted in the GDM rack and detects and evaluates the central operating state of all fiber-optic interfaces. The results is made available at the digital outputs of CP52M0 for further analysis.

7.3.2 Control and display elements

LED displays

The CP52M0 GDM memory module is equipped with 8 LEDs.

H1 and H2 provide information on the current operating state of the CP52M0 GDM memory module

Table 7-9 LED displays of the CP52M0 GDM memory module

LED designation (color)	Function
H1 (green) and H2 (red)	Module status display
H3 (green) and H4 (red)	Display of error states (see Status and fault displays (Page 133))
H5 (green) and H6 (red)	
H7 (green) and H8 (green)	

Front panel

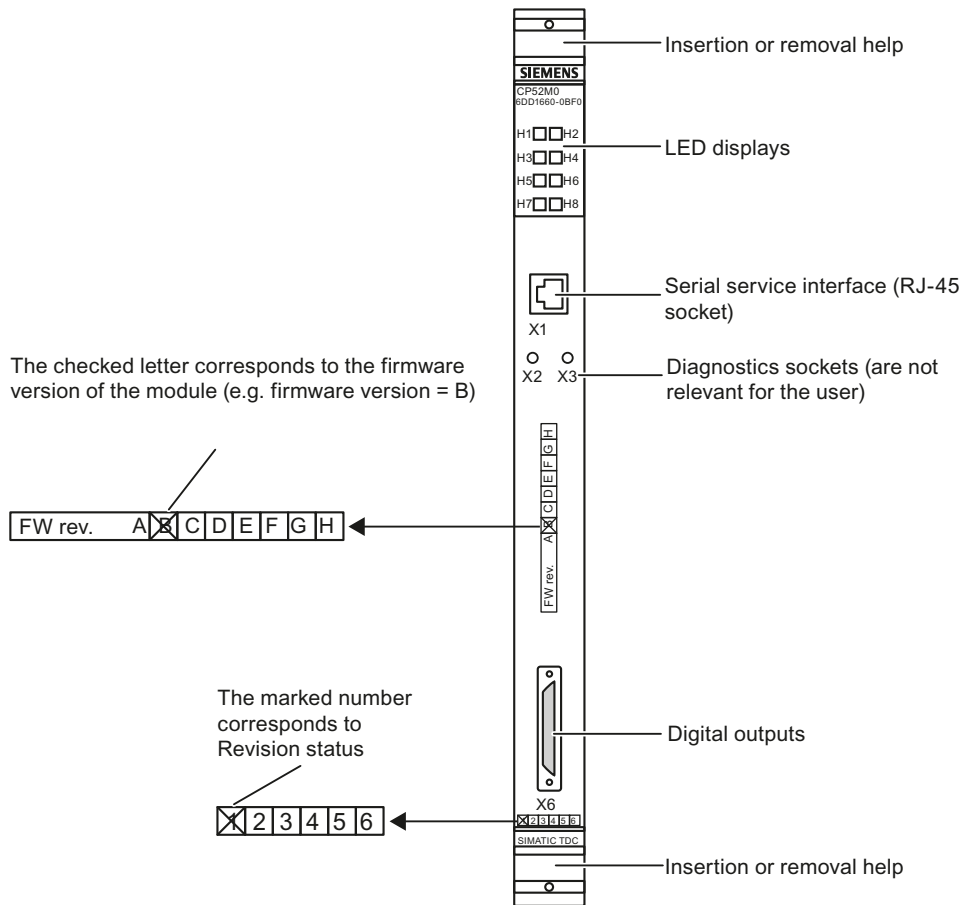

Figure 7-6 Front panel of CP52M0

7.3.3 Status and fault displays

Status displays for CP52M0

Table 7-10 LED status displays for the CP52M0 GDM memory module

LED display		Status of the CP52M0 module
H1	H2	
Off	Off	During voltage run-up
Off	On	All FPGAs in the GDM rack (CP52M0 and CP52IO) are parameterized; the module is initialized
On	Off	The module is initialized and operates without errors
On	On	After 3.3 V or 2.5 V voltage failure <ul style="list-style-type: none"> Hardware failure => Switch off the rack and replace CP52M0

Status displays at the digital outputs

Table 7-11 Status displays at the digital outputs of CP52M0

Digital output	Display/status
DA01 to 11	Indicate the CP52IO slot (slots 2-12) from which the operating state of the four fiber-optic interfaces is displayed on DA12-DA15. The operating state display of the individual CP52IO modules is cycled at seconds intervals.
DA12 to 15	Indicate the operating state of the four fiber-optic interfaces of a CP52IO (DA12 fiber-optic interface 1, DA13 fiber-optic interface 2, etc.). <ul style="list-style-type: none"> Logical status "1" => FOC interface is OK Logical status "0" => Error at FOC interface, or CP52IO is missing
DA16	<ul style="list-style-type: none"> Logical status "1" => RUN operating state Logical status "0" => STOP operating state

Fault displays of CP52M0

Table 7-12 Status and fault displays of CP52M0

LED display		Error states
H3	Flashing	Monitoring error <ul style="list-style-type: none"> Non-critical error during initialization; normal operation may be started.
H4	Flashing	Initialization error <ul style="list-style-type: none"> The start of normal operation is prevented if system initialization errors were found. Initialization error due to incorrect insertion of CP52M0. => The module must be inserted in slot 1.
H5	-	No function
H6	Flashing	System error <ul style="list-style-type: none"> STOP operating state (fatal system fault): Hardware or software problems causing a program crash.
H7	Flashing	Communication error <ul style="list-style-type: none"> Communication error: Incorrect configuration of communication or communication connection
H8	Flashing	Task Manager error The following errors are possible: <ul style="list-style-type: none"> <i>Cycle errors</i> A task could not be completed within the sampling time. <i>Task overflow</i> If the task is not assigned top priority, but needs to be restarted. <i>No free local buffer</i> The data buffer is no longer released. The task start will be skipped. <i>Software time monitoring</i> If the basic sampling time is not processed four times in succession. The basic clock cycle timer is re-initialized with the configured basic sampling time and processing continued.

7.3.4 Application notes and immunity to interference

Application notes

- CP52M0 must be inserted **in slot 1** of the rack (UR5213 or UR6021).
- You may only use **one CP52M0** in the rack.
- The module may not be inserted or removed while the rack is on live voltage.

NOTE

Additional circuit for lightning and overvoltage protection

Please note the following concerning the use of the external 24V power supply for the digital outputs of the the module in accordance with IEC61000-4-5:

- An external circuit is necessary (see also section "General technical specifications, design and EMC directives [\(Page 13\)](#)")
 - In addition to the overvoltage protection, two additional suppressor diodes have to be installed on the 24V supply voltage of the CP52M0.
-

Immunity to interference

Interference-proof operation is only possible if the CP52M0 is firmly attached to the rack. Insert the module and then bolt it onto the rack accordingly (two screw heads, see "Control and display elements [\(Page 139\)](#)").

NOTE

Fan operation, EMC and environmental conditions

- For more information on fan operation, refer to chapter "Rack [\(Page 43\)](#)".
 - For more information on EMC and environmental conditions, refer to chapter "General technical specifications [\(Page 41\)](#)".
-

Wiring the diode

NOTE

The suppressor diode 1.5KE36CA is bidirectional, and for this reason the polarity is unimportant.

1. Install a suppressor diode between the shield and +24 .
2. Install a suppressor diode between the shield and M (ground).

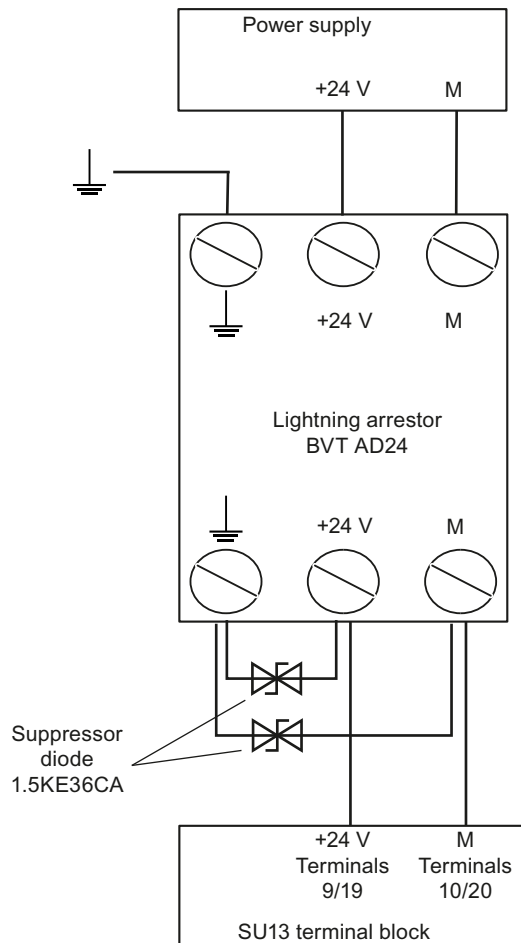

Figure 7-7 Circuit for the suppressor diodes on the lightning arrester

Additional components

The following additional components are available:

- **Surge arrester BLITZDUCTOR VT**
 Type: BTV AD 24
 available under the number: 918 402
 DEHN + SÖHNE GmbH + Co KG
 Postfach 1640
 92306 Neumarkt, Germany
- **Suppressor diode**
 Type: 1.5KE36CA (1500W)
 Manufacturer: e.g. STMicroelectronics, Vishay

7.3.5 Connection options

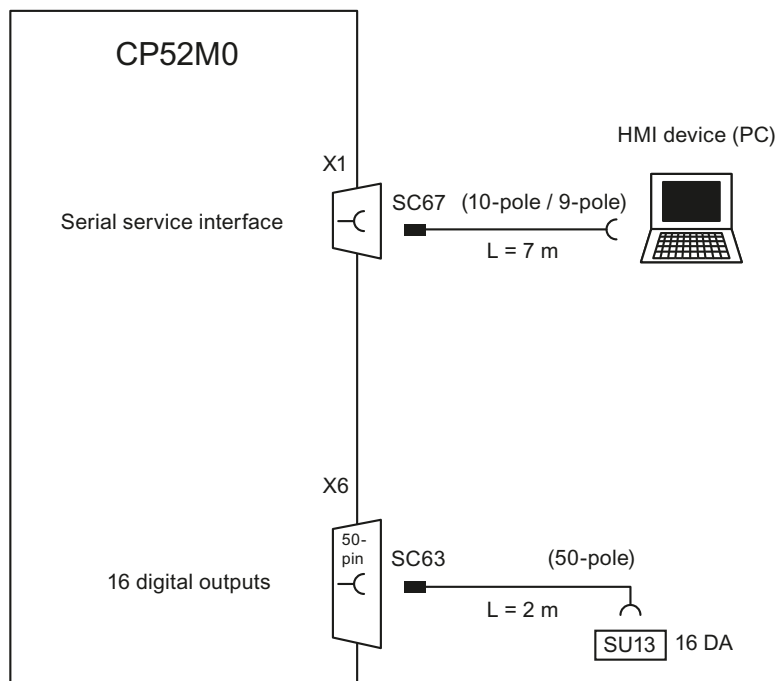

Figure 7-8 Connection options of CP52M0

7.3.6 Additional components

Table 7-13 Additional components for CP52M0

Component	Designation	Article number
Cable for digital outputs (50-pole/50-pole)	SC63	6DD1684-0GDO
PC connecting cable (10-pole/9-pole)	SC67	6DD1684-0GH0
Interface module Direct wiring (1:1 wiring), 50 screw terminals, no signal conversion	SU13	6DD1681-0GK0

7.3.7 Pin assignments

Serial service interface (X1)

A control or configuration PC is connected to the 10-pin RJ-45 jack with polarity reversal protection using the SC67 PC cable.

Table 7-14 Pin assignment of X1 and cable SC67

X1		SC67	
PIN	Designation	PIN CPU side	PIN PC side
1	DCD (Data Carrier Detect)	n.c.	n.c.
2	RxD (Receive Data)	2	3
3	TxD (Transmit Data)	3	2
4	DTR (Data Terminal Ready)	n.c.	n.c.
5	GND (Ground)	5	5
6	DSR (Data Set Ready)	n.c.	n.c.
7	RTS (Request to Send)	n.c.	n.c.
8	CTS (Clear to Send)	n.c.	n.c.
9	RI (Ring Indicator)	n.c.	n.c.
10	(n.c.)	n.c.	

n.c.: not connected

Connector X6 with cable SC63

The assignment of the screw terminals on interface module SU13 corresponds to the pin assignment of X6.

Table 7-15 Pin assignment of X6

X6	Designation	SU13	X6	Designation	SU13
1	Digital output 1	1	26	n.c.	26
2	Digital output 2	2	27	n.c.	27
3	Digital output 3	3	28	n.c.	28
4	Digital output 4	4	29	n.c.	29
5	Digital output 5	5	30	n.c.	30
6	Digital output 6	6	31	n.c.	31
7	Digital output 7	7	32	n.c.	32
8	Digital output 8	8	33	n.c.	33
9	Ext. power supply +24V	9	34	n.c.	34
10	External ground	10	35	External ground	35
11	Digital output 9	11	36	n.c.	36
12	Digital output 10	12	37	n.c.	37
13	Digital output 11	13	38	n.c.	38
14	Digital output 12	14	39	n.c.	39
15	Digital output 13	15	40	n.c.	40
16	Digital output 14	16	41	n.c.	41
17	Digital output 15	17	42	n.c.	42
18	Digital output 16	18	43	n.c.	43
19	Ext. power supply +24V	19	44	n.c.	44
20	External ground	20	45	External ground	45
21	n.c.	21	46	n.c.	46
22	n.c.	22	47	n.c.	47
23	n.c.	23	48	n.c.	48
24	n.c.	24	49	n.c.	49
25	n.c.	25	50	n.c.	50
n.c.: not connected					

7.3.8 Technical specifications/performance features

Article number

GDM memory module CP52M0	6DD1660-0BF0
--------------------------	--------------

Memory

SRAM	2 MB
------	------

Interfaces

Serial service interface (X1) • Transmission rate	RS232 interface (V.24) • 19.2 Kbps
--	---------------------------------------

Digital outputs

Number	16
Electrical isolation	No
External power supply • Rated voltage • Perm. range • short-term • Current consumption, max., no load	24 V 20.4 V to 28.8 V 35 V (for max. 0.5 s) 40 mA
Output voltage range • With 0 signal, max. • With 1 signal, min.	3 V Ext. supply voltage – 2.5 V
Output current • With 0 signal, min. • at 1 signal • Rated value • Valid range, max.	-20 µA 50 mA 100 mA
Delay time	100 µsec
Switching frequency of outputs With resistance load, max.	6 kHz
Short-circuit protection to • Ground • External power supply	yes No
Short-circuit current, max.	250 mA
Total current of outputs (up to 60 °C)	16 x 50 mA
Limiting of inductive cut-off voltages	Ext. supply voltage +1 V

Voltage, currents

Rated voltages at 25 °C	Typical current consumption
+5 V	0.4 A
+3.3 V	0.7 A
+12 V	10 mA
-12 V	10 mA

Power losses/fan

Typical power losses	4.5 W
Fan required	No

Dimensions

Number of slots required in the rack	1
Dimensions W x H x D [mm]	20 x 233 x 160
Weight, approx.	0.4 kg

7.4 CP52IO GDM interface module

7.4.1 Areas of application

GlobalDataMemory

GlobalDataMemory (GDM) enables data exchange between **all** CPU modules in all racks of the system.

Since central memory supports the synchronous coupling of up to 44 racks, it is possible to operate up to 836 CPU modules in a maximum system configuration.

A separate rack is used for GDM. The CP52M0 memory module (slot 1) and an appropriate number of **CP52IO interface modules (slots 2-12)** are accommodated in the UR5213 or UR6021 racks with 21 slots.

Each rack that is coupled with GDM must be equipped with a CP52A0 access module. These racks are interconnected with GDM by means of fiber-optic cables in a star topology.

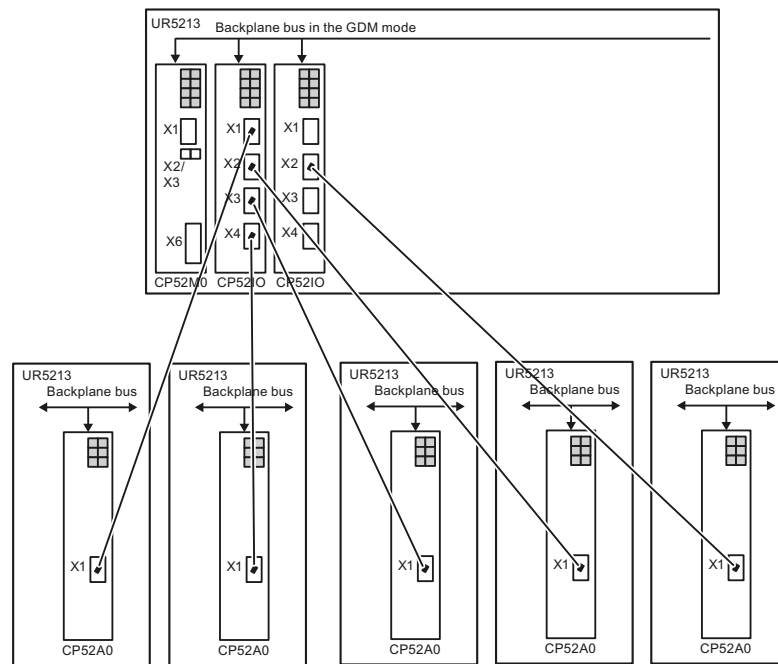

Figure 7-9 Example of a GDM system with 5 racks that are coupled with FOCs

7.4.2 Control and display elements

LED displays

The CP52IO GDM interface module is equipped with 8 LEDs. These indicate whether or not valid frames are received or transmitted at GDM access module CP52A0.

Table 7-16 LED displays of the CP52IO GDM interface module

LED designation (color)	Function
H1 (green)	FOC interface 1 transmits data
H2 (yellow)	FOC interface 1 receives data
H3 (green)	FOC interface 2 transmits data
H4 (yellow)	FOC interface 2 receives data
H5 (green)	FOC interface 3 transmits data
H6 (yellow)	FOC interface 3 receives data
H7 (green)	FOC interface 4 transmits data
H8 (yellow)	FOC interface 4 receives data

Front panel

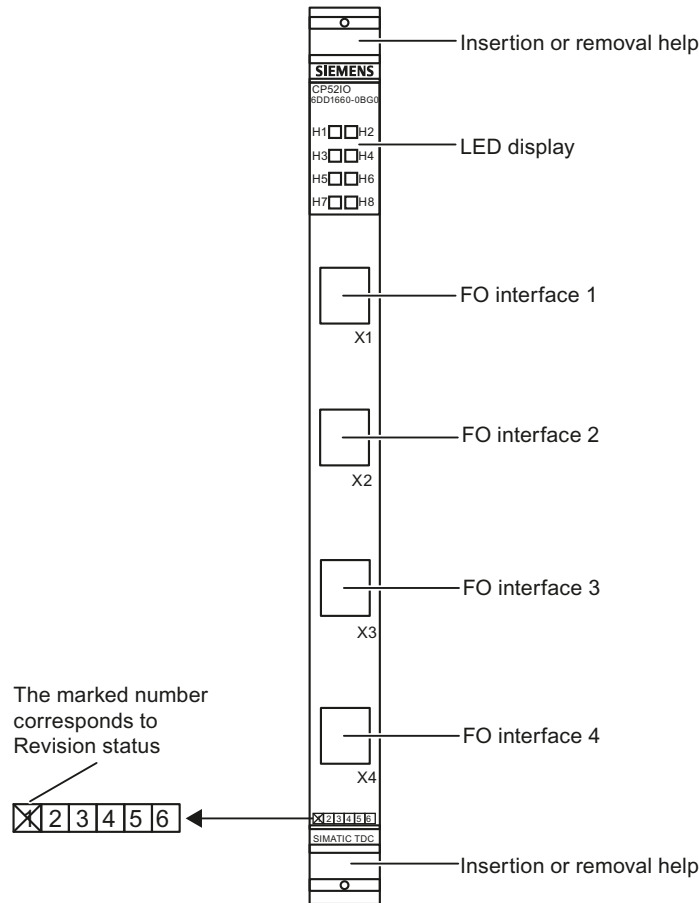

Figure 7-10 Front panel of CP52IO

7.4.3 Status and fault displays

Status displays for CP52IO

Table 7-17 Status and fault displays of the CP52IO GDM interface module

LED display		State
H1	Off	No data transfer to the CP52A0 GDM access module
H3 H5 H7	Glowing ^{*)} /lit	Data transfer to the CP52A0 GDM access module
	Flashing with 0.5 Hz	The CP52IO module is inserted in the wrong slot
H2	Off	Missing or incorrect data transfer from the CP52A0GDM access module
H4 H6 H8	Glowing ^{*)} /lit	Error-free data transfer from the CP52A0 GDM access module
	Flashing with 0.5 Hz	The CP52IO module is inserted in the wrong slot
*) The brightness of the LED indicates the density of periodic data traffic.		

7.4.4 Application notes and immunity to interference

The CP52IO GDM access modules in the racks are connected to the CP52A0 GDM interface module via fiber-optic cables (FOC). Up to four racks can be connected to each CP52IO.

- The CP52IO modules must be inserted between **slots 2 and 12**.
- Free slots between the individual modules are allowed.
- The rack may be equipped with a maximum of 11 CP52IO interface modules.
- Modules may not be inserted in slots 13 - 21.
- You may insert the fiber-optic cables into the FOC interfaces of CP52IO to suit your application.
- It is not necessary to occupy all FOC interfaces of CP52IO.
- Memory access rates do not depend on which CP52IO the fiber-optic cable is connected, as all FOC interfaces are assigned the same priority.
- Interference-proof operation is only possible if the CP52IO is firmly attached to the rack. Insert the module and then bolt it onto the rack accordingly (two screw heads, see "Control and display elements (Page 150)").
- The module may not be inserted or removed while the rack is on live voltage.
- Removal and insertion of the fiber-optic cables is not permitted during operation.

NOTE

See also:

- For more information on fan operation, refer to chapter "Rack (Page 43)".
 - For more information on EMC and environmental conditions, refer to chapter "General technical specifications (Page 41)".
-

7.4.5 Connection options

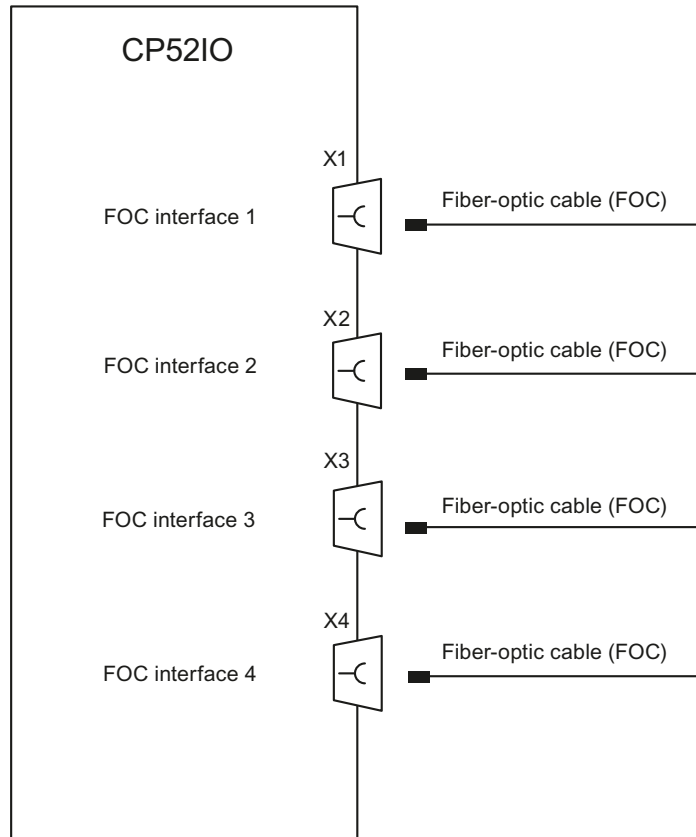

Figure 7-11 Connection options of CP52IO

7.4.6 Additional components

Fiber-optic cable (FOC)

A fiber-optic cable with a **core diameter of 62.5 μm /125 μm** is used to interconnect the CP52A0 GDM access module with the CP52IO GDM interface module. The cables are connected using **Duplex SC connectors**.

The **max. cable length** for the connection between CP52IO and CP52A0 is **200 m**.

The fiber-optic cables must be assembled in accordance with the plant topology and can be ordered from the following supplier:

Ehret GmbH
Über der Elz 2
79312 Emmendingen

7.4.7 Pin assignments

FOC interfaces X1 to X4

The fiber-optic cables are connected to the front connectors X1 to X4 by means of Duplex SC connector.

7.4.8 Technical specifications/performance features

Article number

CP52IO GDM interface module	6DD1660-0BG0
-----------------------------	--------------

Interface

FOC interface	
<ul style="list-style-type: none"> • Number • Data transmission speed • Code • Checksum test 	<ul style="list-style-type: none"> • 4 • 640 Mbps • 8B/10B • CRC

Voltage, currents

Rated voltages at 25 °C	Typical current consumption
+5 V	3.0 A
+3.3 V	0.8 A

Power losses/fan

Typical power losses	18 W
Fan required	yes

Dimensions

Number of slots required in the rack	1
Dimensions W x H x D [mm]	20 x 233 x 160
Weight	0.4 kg

7.5 CP52A0 GDM access module

7.5.1 Areas of application

GlobalDataMemory

GlobalDataMemory (GDM) enables data exchange between **all** CPU modules in all racks of the system.

Since central memory supports the synchronous coupling of up to 44 racks, it is possible to operate up to 836 CPU modules in a maximum system configuration.

A separate rack is used for GDM. The CP52M0 memory module (slot 1) and an appropriate number of CP52IO interface modules (slots 2-12) are accommodated in the UR5213 or UR6021 racks with 21 slots.

Each rack that is coupled with GDM must contain a **CP52A0 access module**. These racks are interconnected with GDM by means of fiber-optic cables in a star topology.

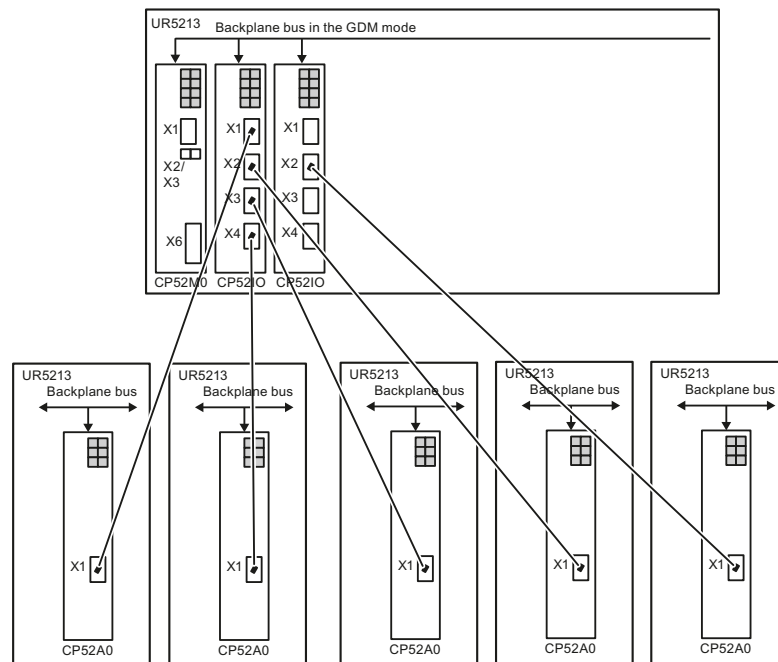

Figure 7-12 Example of a GDM system with 5 racks that are coupled with FOCs

7.5.2 Using the CP52A0 - 6DD1660-0BH1

Please note the following when using the GDM access module CP52A0 with article number 6DD1660-0BH1.

NOTE

CP52A0 with article number 6DD1660-0BH1

The use of a GDM access module CP52A0 with article number 6DD1660-0BH1 requires a CP52IO with at least functional status 7 on the receiver side.

7.5.3 Control and display elements

LED displays

The CP52A0 GDM access module is equipped with six LEDs that provide information on the current operating state of the module.

Table 7-18 LED displays of the CP52A0 GDM access module

LED designation (color)	Function
H1 (green)	Operating state of the CP52A0 GDM access module
H2 (red)	
H3 (green)	FOC interface is transmitting data
H4 (yellow)	FOC interface is receiving error-free data
H5 (green)	Startup ID
H6 (yellow)	Send authorization for clock triggers or base sampling time

Front panel

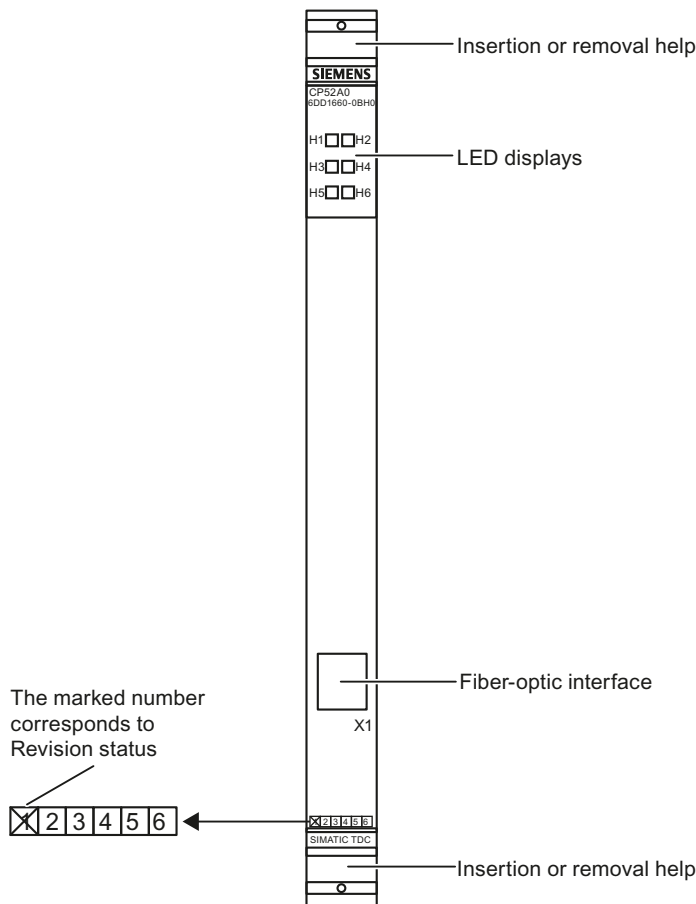

Figure 7-13 Front panel of CP52A0

7.5.4 Status and fault displays

Status displays for CP52A0

Table 7-19 Status displays for the CP52A0 GDM access modules

LED display		Module status
H1	H2	
Off	Off	During voltage run-up
Off	On	FPGAs are configured, module is not initialized
On	Off	Module is initialized and operating error-free
On	On	After 3.3 V or 2.5 V voltage failure <ul style="list-style-type: none"> Hardware failure => Switch off the rack and replace CP52A0

Status displays for communication

Table 7-20 Status and fault displays of the CP52A0 GDM access module

LED display		State
H3	Off	No data transmission to the CP52IO GDM interface module
	Glowing ^{*)} /lit	Data transmission to the CP52IO GDM interface module
H4	Off	Missing or faulty data transmission from the CP52IO GDM interface module
	Glowing ^{*)} /lit	Error-free data transmission from the CP52IO GDM interface module
H5	Off	No ramp-up ID from the CP52IO GDM interface module
	On	Ramp-up ID set
H6	Off	Clock trigger and base sampling time are parameterized and have send authorization from CP52IO
	On	The clock trigger and basic sampling time have been parameterized for transmission but have no transmit authorization from the CP52IO (priority logic is inhibiting one of the two signals)

^{*)}The brightness of the LED indicates the density of periodic data traffic.

7.5.5 Application notes and immunity to interference

- The entire user application is configured in the racks that contain the access modules.
- The trigger signals, clock trigger and base sampling time can only be sent independently of one another from one CP52A0. CP52A0 supports transmission and receiving of these signals. HWConfig is used to define whether the module receives or sends.
- If the clock trigger and basic sampling time were configured for transmission on several access modules, the trigger signal is always transmitted from the CP52A0 that is connected with a CP52IO whose FOC interface is located on the extreme top left in the rack (refer to the example of priority logic).

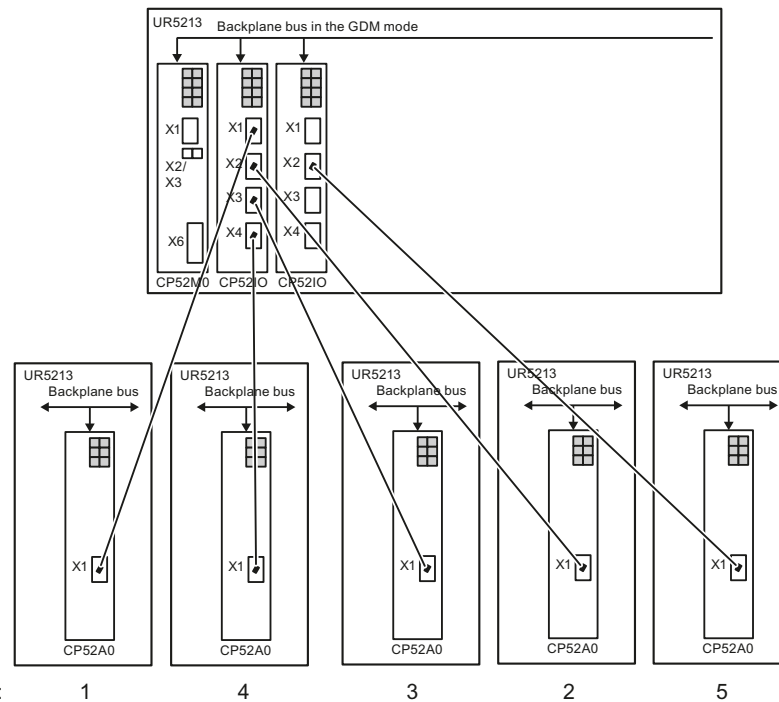

- The SYSFAIL* and alarm trigger signals can be simultaneously sent and received from every CP52A0.
- Interference-proof operation is only possible if the CP52M0 is firmly attached to the rack. Insert the module and then bolt it onto the rack accordingly (two screw heads, see "Control and display elements (Page 156)").
- The module may not be inserted or removed while the rack is on live voltage.
- Removal and insertion of the fiber-optic cables is not permitted during operation.

NOTE

See also:

- For more information on fan operation, refer to chapter "Rack (Page 43)".
- For more information on EMC and environmental conditions, refer to chapter "General technical specifications (Page 41)".

7.5.6 Connection options

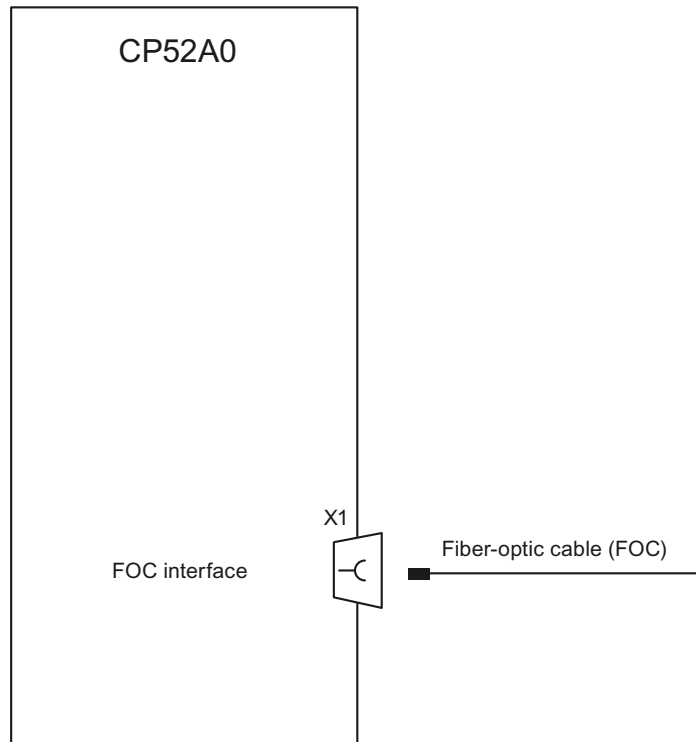

Figure 7-14 Connection options of CP52A0

7.5.7 Additional components

Fiber-optic cable (FOC)

A fiber-optic cable with a **core diameter of 62.5 μm /125 μm** is used to interconnect the CP52A0 GDM access module with the CP52IO GDM interface module. The cable is connected by means of **Duplex SC connectors**.

The **max. cable length** for the connection between CP52IO and CP52A0 is **200 m**.

The fiber-optic cables must be assembled in accordance with the plant topology and can be ordered from the following supplier:

Ehret GmbH
Über der Elz 2
79312 Emmendingen

7.5.8 Pin assignments

Fiber-optic cable interfaces X1

The fiber-optic cables are connected via a Duplex SC connector at connector X1 on the front panel

7.5.9 Technical specifications/performance features

Article number

CP52A0 GDM access module	6DD1660-0BH0 / 6DD1660-0BH1
--------------------------	-----------------------------

Interface

FOC interface <ul style="list-style-type: none"> • Number • Data transmission speed • Code • Checksum test 	1 640 Mbps 8B/10B CRC
--	--------------------------------

Voltage, currents

Rated voltages at 25 °C	Typical current consumption
+5 V	1.5 A
3.3 V	0.4 A

Power losses/fan

Typical power losses	9 W
Fan required	No

Dimensions

Number of slots required in the rack	1
Dimensions W x H x D [mm]	20 x 233 x 160
Weight	0.3 kg

7.6 CP53M0 coupling module

7.6.1 Areas of application

Rack coupling

Coupling module CP53M0 is used to couple a SIMATIC TDC system to a SIMADYN D system for high-speed data exchange, e.g. when expanding SIMADYN D systems.

CP53M0 is equipped with a buffer memory for data exchange between the CPU modules in the rack.

The CP53M0 can be parameterized as master or slave for data exchange with other racks.

7.6.1.1 CP53M0 as slave

CP53M0 is parameterized in HW Config for operation in slave mode. A CS12/CS13/CS14 in a SIMADYN D rack can be connected to the FOC connectors X1/X2. Additional CS22 or CP53M0 can be connected to the other connectors of CS13/CS14.

The FOC connectors X3/X4 do not have any function in this mode.

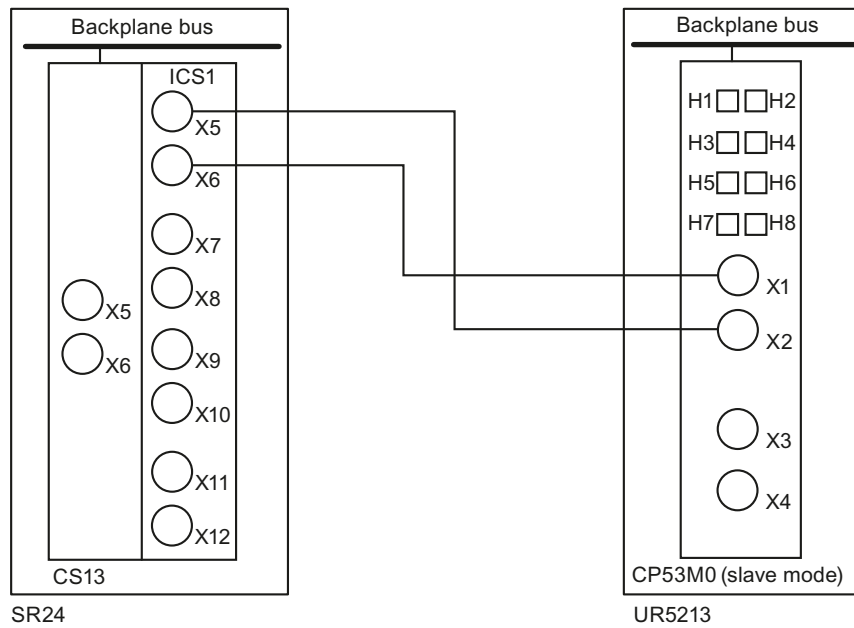

Figure 7-15 Options for connecting CP53M0 as slave to the CS13

Table 7-21 Pin assignment of CP53M0 operated on the SIMADYN D module CS13 and CS14

ICS1	CP53M0 (1)	CP53M0 (2)	CP53M0 (3)	CP53M0 (4)
X5	X2			
X6	X1			
X7		X2		
X8		X1		
X9			X2	

ICS1	CP53M0 (1)	CP53M0 (2)	CP53M0 (3)	CP53M0 (4)
X10			X1	
X11				X2
X12				X1
	X3 (no function)			
	X4 (no function)			

The listing in the "Pin assignments of CP53M0 an SIMADYN D modules CS13 and CS14" table above also applies to the second ICS1 on CS14.

If less than four slave modules are connected to an ICS1, the fiber-optic cables can be inserted as required in pairs.

7.6.1.2 CP53M0 as master

CP53M0 is parameterized in HW Config for operation in master mode (default). In this mode, two slave modules can be connected to CP53M0 (CS22 or CP53M0 (parameterized as slave)).

Example 1

Connecting two SIMADYN D CS22 modules to CP53M0

One CS22 is connected to each of the FOC connectors X1/X2 or X3/X4 in a SIMADYN D rack.

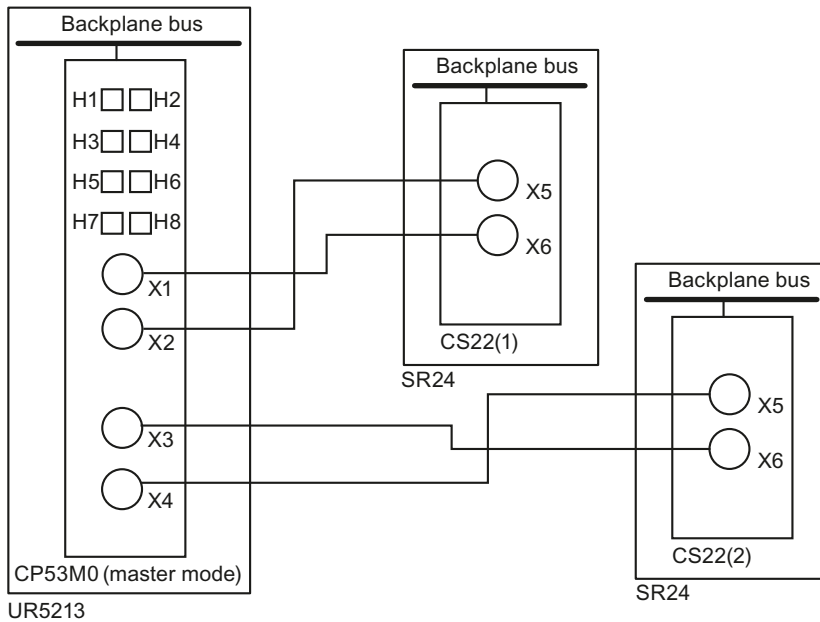

Figure 7-16 Options for connecting the CS22 to CP53M0 that is operating in master mode

Table 7-22 Pin assignment of two CS22 on a CP53M0

CP53M0	CS22(1)	CS22(2)
X1	X6	
X2	X5	
X3		X6
X4		X5

Example 2

Coupling SIMATIC TDC racks

CP53M0 can be used to couple up to three SIMATIC TDC racks. In this case, CP53M0 is parameterized for operation in master mode in one rack and in slave mode in the other two racks.

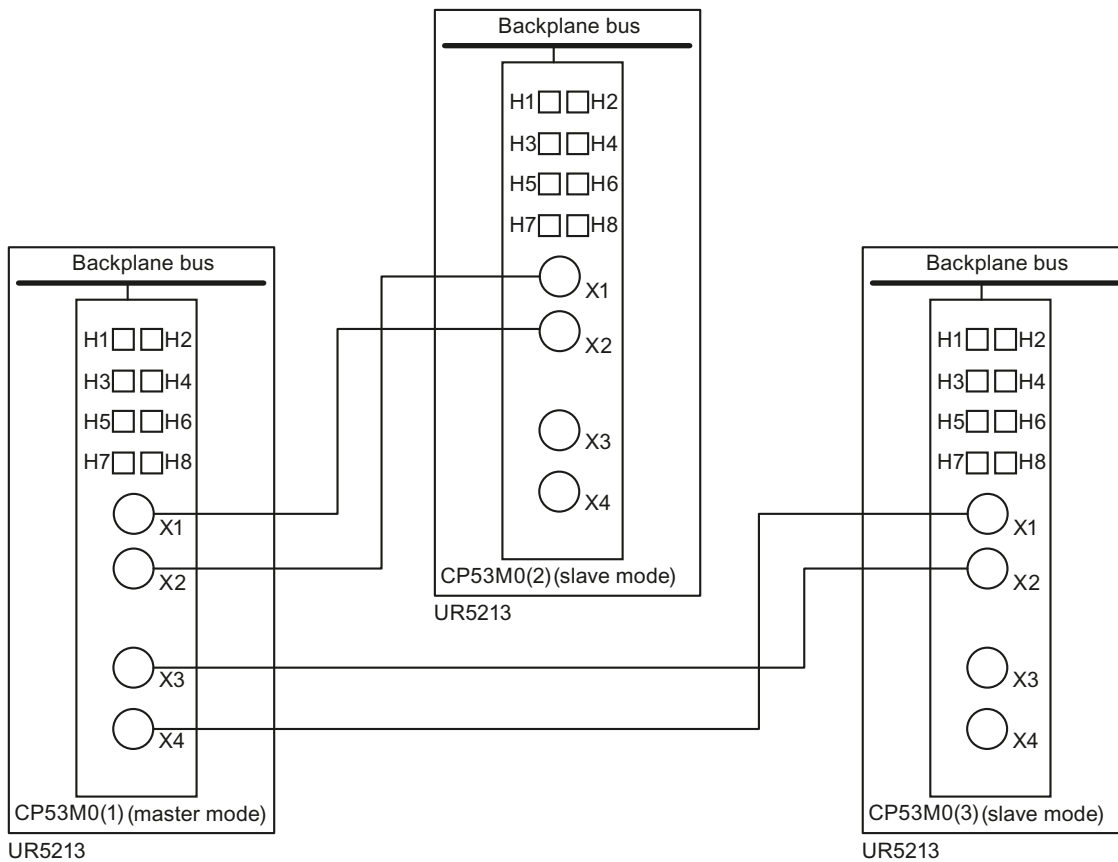

Figure 7-17 Coupling three SIMATIC TDC racks

Table 7-23 Options of connecting two CP53M0 slaves to a CP53M0 master

CP53M0 (1)	CP53M0 (2)	CP53M0 (3)
X1	X2	
X2	X1	
X3		X2

CP53M0 (1)	CP53M0 (2)	CP53M0 (3)
X4		X1
	X3 (no function)	
	X4 (no function)	

7.6.2 Control and display elements

LED displays

The CP53M0 coupling module is equipped with 8 LEDs that provide information on the current operating state of the module.

Table 7-24 LED displays of the CP53M0 coupling module

LED designation (color)	Function
H1 (green)	Operating state of coupling module CP53M0
H2 (red)	
H3 (green)	Status startup frame to X1/X2
H4 (yellow)	Data transmission to X1/X2
H5 (green)	Status startup frame to X3/X4
H6 (yellow)	Data transmission to X3/X4
H7 (green)	Status fiber-optic cable link to X1/X2
H8 (green)	Status fiber-optic cable link to X3/X4

Front panel

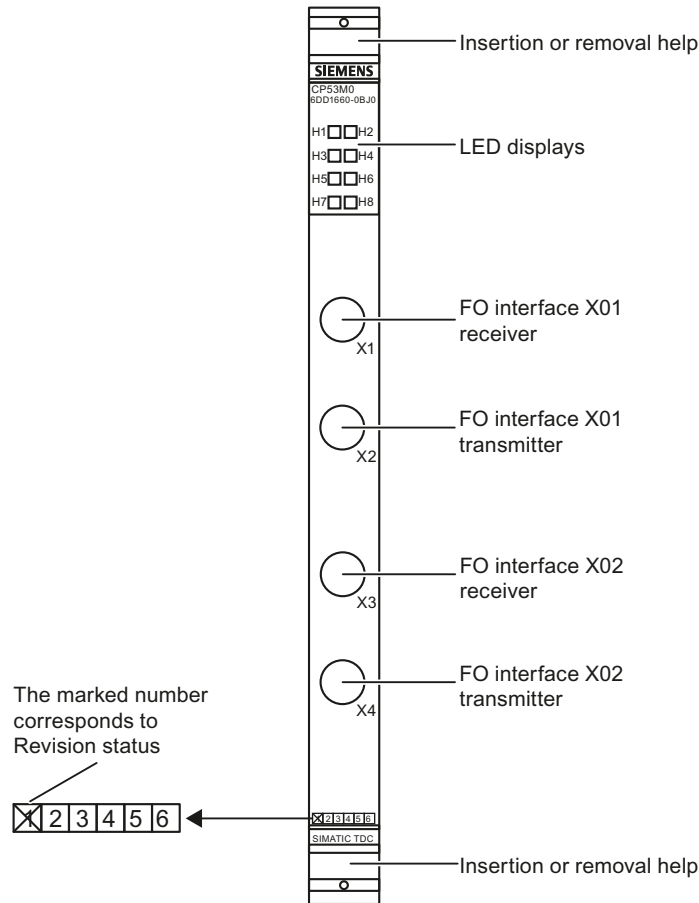

Figure 7-18 Front panel of CP53M0

7.6.3 Status and fault displays

Status displays for CP53M0

Table 7-25 Status displays for coupling module CP53M0

LED display		Module status
H1	H2	
Off	Off	During voltage run-up
Off	On	FPGAs are configured, module is not initialized
On	Off	Module is initialized and operating error-free
On	On	After 3.3, 2.5 V or 1.2 V voltage failure <ul style="list-style-type: none"> Hardware failure => Switch off the rack and replace the CP53M0

Status displays for communication

Table 7-26 Status and fault displays of coupling module CP53M0

LED display		State
H3	Off	Master mode: CP53M0 is not transmitting a startup frame to X1/2 Slave mode: CP53M0 is not receiving a startup frame via X1/X2
	On	Master mode: CP53M0 is transmitting startup frames to X1/2 Slave mode: CP53M0 is receiving startup frames via X1/X2
H4	Off	Master mode: No acknowledgment of data access from the slave at X1/X2 Slave mode: No acknowledgment of data access at X1/X2
	Glowing*)	Master mode: Acknowledgment of data access from the slave at X1/X2 Slave mode: Acknowledgment of data access at X1/X2
H5	Off	Master mode: CP53M0 is transmitting startup frames at X3/4 Slave mode: No function
	On	Master mode: CP53M0 is transmitting startup frames at X3/4 Slave mode: No function
H6	Off	Master mode: No acknowledgement of data access from the slave at X3/X4 Slave mode: No function
	Glowing*)	Master mode: Acknowledgment of data access from the slave at X1/X2 Slave mode: No function
H7	Off	Receiver, FOC interface X1/X2 has no valid receive signals
	On	Receiver, FOC interface X1/X2 has a valid receive signal
H8	Off	Master mode: Receiver FOC interface X3/X4 has no valid receive signal Slave mode: No function
	On	Master mode: Receiver FOC interface X3/X4 has valid receive signal Slave mode: No function
*) The brightness of the LED indicates the intensity of periodic data traffic.		

7.6.4 Application notes and immunity to interference

- If CP53M0 is operated in master mode, the clock trigger, alarm trigger, or basic sampling time trigger signals are transmitted.
- These signals are received on the CP53M0 in slave mode and routed to the backplane bus in accordance with the parameterization in HWConfig or CFC configuration (clock trigger).
- A CS22 at a CP53M0 in master mode receives the clock trigger, alarm trigger, or basic sampling time trigger signals.
- A CP53M0 in slave mode on a CS12/CS13/CS14 receives the clock trigger, alarm trigger, or basic sampling time trigger signals.
- If several CP53M0 in the same rack are configured for operation in slave mode and route the alarm interrupt to the backplane bus, the CPU cannot identify the CP53M0 that triggered the alarm interrupt.
- Interference-proof operation is only possible if the CP53M0 is firmly attached to the rack. Insert the module and then bolt it onto the rack accordingly (two screw heads, see "Control and display elements (Page 164)").
- The racks may be switched on and off independently. The coupling is automatically restored.
- The module may not be inserted or removed while the rack is on live voltage.
- Before switching on power to a rack, verify that all connectors of the FOC couplings involved have been inserted.
- Removal and insertion of the fiber-optic cables is not permitted during operation.
- If no fiber-optic cables are inserted, protect the transmit and receive terminals using appropriate caps.

NOTE

See also:

- For more information on fan operation, refer to chapter "Rack (Page 43)".
 - For more information on EMC and environmental conditions, refer to chapter "General technical specifications (Page 41)".
-

7.6.5 Connection options

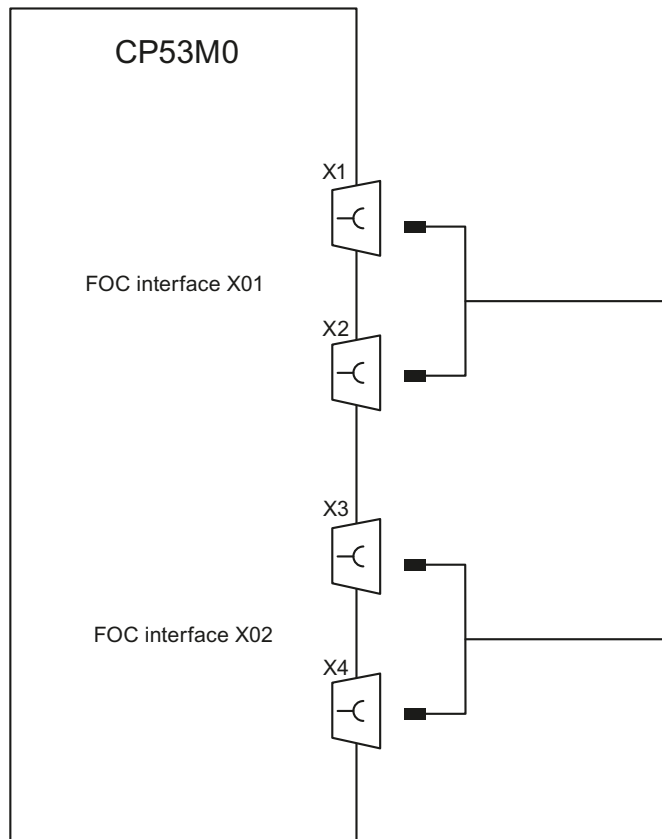

Figure 7-19 Connection options of CP53M0

7.6.6 Additional components

Fiber-optic cable (FOC)

The following cable is used to connect communication module CP53M0 to an additional CP53M0, or to a CS12/CS13/CS14/CS22:

SIMATIC NET, STANDARD FIBER-OPTIC CABLE, SPLITTABLE, DRESSED WITH 4 x BFOC CONNECTORS

Article number: 6XV1820-5Bxyz (xyz: length code)

For information on available lengths, refer to the interactive catalog in the A&D MALL.

The **max. cable length** is **300 m**.

7.6.7 Pin assignments

FOC connectors X1 – X4

The FOC cables are connected by means of BFOC connector to the front connectors X1-X4. For more information, refer to chapter "Areas of application".

7.6.8 Technical specifications/performance features

Article number

CP53M0 coupling module	6DD1660-0BJ0
------------------------	--------------

Memory

Communication memory	SRAM, 128 KB
Buffer memory module	SDRAM, 8 MB, 1 MB of which for buffer memory coupling (e.g. CRV, CTV blocks) You can find additional information in the System and Communication Configuration D7-SYS system manual, in the section Buffer memory coupling.

NOTE

If several CPxxMx are used in a rack, only the CPxxMx on the extreme left has the buffer memory function.

Interface

FOC interface	
• Number	2 (master mode) 1 (slave mode)
• Data transmission speed	96 Mbps
• Code	5B/6B

Voltage, currents

Rated voltages at 25 °C	Typical current consumption
+5 V	0.3 A
3,3 V	0.5 A

Power losses/fan

Typical power losses	3.1 W
Fan required	No

Dimensions

Number of slots required in the rack	1
Dimensions W x H x D [mm]	20 x 233 x 160
Weight	0.4 kg

Interface module

8.1 Interface module SB10

Article number

6DD1681-0AE2

Description

The interface module transfers digital signals from SIMATIC TDC components to the system, or receives digital signals from the system and transfers these to SIMATIC TDC components. The connection to SIMATIC TDC components is realized via the cables SC62 or SC66 and via terminals on system side. There is no electrical isolation between the SIMATIC TDC components side and system side.

Module design

- Enclosure for snap-on mounting to rails
- Ribbon cable connector (X1):
 - 8 pins for digital signals, 24 V DC
 - 2 pins for 1P, 1M supply voltages
- Connector (X2), 2 x 8-pole:
 - 8 terminals for 24 V DC digital signals
 - 8 terminals for reference potentials (1M, 1P is also possible)
- 1 terminal pair X3: 1P and 1M
- Double test socket X5: 1P(+), 1M(G)
- LED displays for diagnostics

Voltage supply on SIMATIC side

The SIMATIC TDC voltage supply is fed to terminal X3:

Terminal X3	Voltage SIMATIC side
1P	+24 V
1M	0 V

Connect the cables using accessory kit SM11 "Power supply connector for interface modules" (article number: 6DD1680-0BB0)

The maximum conductor cross-section at terminal X3 is 2.5 mm².

Green LED

The voltage supply on SIMATIC TDC side is indicated by a green LED (P).

Red LED

The supply voltage on SIMATIC TDC side (1P, 1M) is short-circuited (fault).

Test socket

Voltages 1P and 1M can be used via the double test socket (G; +) to simulate an input signal for SIMATIC TDC.

Double test socket X5	Voltage
+ (1P of X3)	+24 V
G (1M of X3)	0 V

WARNING

Explosion hazard

It is not allowed to use the X5 test sockets in potentially explosive environments.

NOTE

When wiring the supply voltage, observe the "Installation and EMC Directives" chapter in the User Manual.

8.1.1 Signals

Yellow LED

The status of each of the 8 signals (1...8) is displayed by means of a yellow LED. Each signal is provided a screw terminal on the two terminal blocks X2:

- Terminals 1 to 8 for digital signals
- Terminals 51 to 58 for reference points

Reference potential of the signals

The reference points of the signals may be derived from 1M or 1P potential. The polarity is selected on the module by means of soldering bridge:

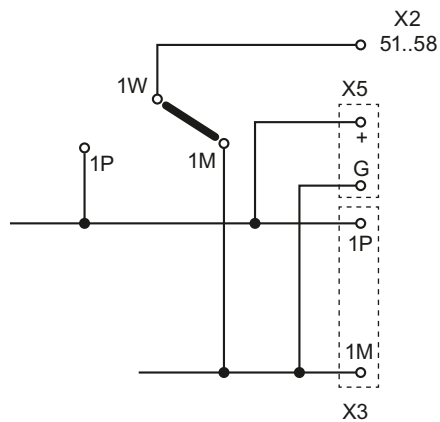

Figure 8-1 Soldering bridge for setting the signal reference points

NOTE

Bridge 1M-1W is inserted in the factory

Power supply

Description	SIMATIC TDC
Supply voltage (V_V) at rated value	24 V DC
Valid range	20.4 V to 28.8 V DC
Briefly $t < 500$ ms	$1.5 \times V_{\text{rated}}$
Current consumption	
	At rated value ¹⁾
	20 mA
	Maximum current per supply line
	400 mA
¹⁾ LED intrinsic consumption without load on system modules	

The maximum current of 1 A may not be exceeded on connector X3 if the supply of several terminal blocks is routed via this connector.

Digital signals

Number	8
Rated voltage	DC 24 V
Maximum current per channel	30 mA

8.1.4 Pin assignment

Ribbon cable connector X1

The cables SC62 or SC66 are used to connect the interface modules to the SIMATIC TDC components (for more information, refer to the SIMATIC TDC Documentation).

Terminal block X2

Table 8-1 Pin assignment of the digital I/O of interface module SB10

Terminal	Designation
1	Channel 1 (digital input/output 1)
2	Channel 2 (digital input/output 2)
3	Channel 3 (digital input/output 3)
4	Channel 4 (digital input/output 4)
5	Channel 5 (digital input/output 5)
6	Channel 6 (digital input/output 6)
7	Channel 7 (digital input/output 7)
8	Channel 8 (digital input/output 8)

Terminal	Designation
51	Reference busbar, 1M (1P can be set)
52	Reference busbar, 1M (1P can be set)
53	Reference busbar, 1M (1P can be set)
54	Reference busbar, 1M (1P can be set)
55	Reference busbar, 1M (1P can be set)
56	Reference busbar, 1M (1P can be set)
57	Reference busbar, 1M (1P can be set)
58	Reference busbar, 1M (1P can be set)

Conductor cross-section

The minimum conductor cross-section for the terminal block X1 is 0.2mm² and the maximum is 2.5 mm².

8.1.5 Block diagram

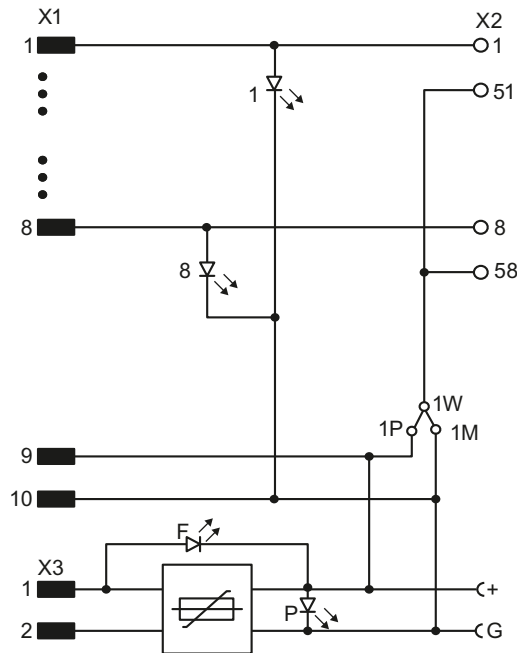

Figure 8-3 Block diagram of interface module SB10

8.2 Interface module SB60

Article number

6DD1681-0AF4

Description

Interface module SB60 is used to adapt 8 digital input signals with electrical isolation to the signal level of SIMATIC TDC by means of optocoupler. The input signal voltage can amount to 120 V DC or AC.

The eight digital inputs and the SIMATIC TDC rack are electrically separated. The eight digital inputs are electrically isolated with respect to one another.

The cables SC62 or SC66 are used to connect the interface modules to the SIMATIC TDC components (for more information, refer to the SIMATIC TDC Documentation).

Module design

- Enclosure for snap-on mounting to rails
- Ribbon cable connector (X1):
 - 8 pins for digital outputs
 - 2 pins for 1P, 1M
- Connector (X2), 2 x 12-pole:
 - 8 terminals for 120 V digital inputs
 - 8 terminals for reference potentials
- 1 terminal pair X3:
 - 1P and 1M for the voltage on SIMATIC side
- LED displays for diagnostics
- Optocoupler for electrical isolation between inputs and outputs

Voltage supply on SIMATIC side

The SIMATIC TDC voltage supply is fed to terminal X3:

Terminal X3	Voltage on SIMATIC TDC side
1P	+24 V
1M	0 V

Connect the cables using accessory kit SM11 "Power supply connector for interface modules" (article number: 6DD1680-0BB0) The maximum conductor cross-section at terminal X3 is 2.5 mm².

NOTE

When wiring the supply voltage, observe the "Installation and EMC Directives" chapter in the User Manual.

WARNING

Safe electrical isolation is guaranteed only between the inputs and outputs

The system side (rack including 24V power supply) is safely isolated from dangerous voltages on plant side (8 output signals).

The input circuits are only galvanically isolated.

The input circuits on plant side are only isolated galvanically. Circuits consisting of combinations of safety extra-low voltage and hazardous voltages are not allowed.

Green LED

The voltage supply (1P, 1M) on SIMATIC side is displayed by a green LED (P).

Red LED

The supply voltage on SIMATIC TDC side (1P, 1M) is short-circuited (fault).

8.2.1 Signals

Signals up to a maximum of 120 V (nominal value) DC or AC can be connected at the SB60 interface module.

Yellow LED

The status of the binary interface module outputs (binary inputs for SIMATIC TDC) is indicated using yellow LEDs (1...8).

Terminal block X2 provides two screw terminals for each signal:

- terminals 12, 22, ... up to 82 for binary signals 120 V
- terminals 11, 21, ... up to 81 for the reference point

NOTE

When wiring the signal lines to the terminals, observe "Installation and EMC Directives" in the User Manual.

8.2.2 Application notes

The interface module is designed **only for vertical mounting positions** due to thermal losses to be dissipated.

Other information

For more information on EMC and environmental conditions, refer to section "General technical specifications (Page 41)"!

8.2.3 Technical specifications

General data

Mounting system	Suitable for snap-on mounting on rails
Dimensions W x H x D [mm]	45 x 129 x 160 mm
Weight	0.3 kg

Ambient temperatures

Ambient temperatures	max. 60 °C
----------------------	------------

Power supply

Supply voltage (V_s) Rated value	24 V DC
Valid range	20.4 V to 28.8 V DC
Briefly $t < 500$ ms	$1.5 \times V_{\text{rated}}$
Rated current consumption	90 mA

The maximum current of 1 A may not be exceeded on connector X3 if the supply of several terminal blocks is routed via this connector.

Digital inputs

Number	8
Nominal input voltage	AC/DC 120 V
'1 signal'	98 V to 132 V
'0 signal'	0 V to 33 V ¹⁾
Input current ('1 signal')	Max. 3 mA
Dielectric strength	Safety isolation guaranteed: - between inputs and outputs Electrical isolation guaranteed: - between input circuits Test voltage 1125 V AC
¹⁾ or open-circuit input	

8.2.4 Pin assignment

Flat connector X1

The cables SC62 or SC66 are used to connect the interface modules to the SIMATIC TDC components (for more information, refer to the SIMATIC TDC Documentation).

Digital inputs terminal block X2

Table 8-2 Pin assignment of the digital inputs of interface module SB60

Terminal	120 V	Channel No.
11	Reference	Channel 1
21	Reference	Channel 2
31	Reference	Channel 3
41	Reference	Channel 4
51	Reference	Channel 5
61	Reference	Channel 6
71	Reference	Channel 7
81	Reference	Channel 8

Terminal	120 V	Channel No.
12	120 V input	Channel 1
22	120 V input	Channel 2
32	120 V input	Channel 3
42	120 V input	Channel 4
52	120 V input	Channel 5
62	120 V input	Channel 6
72	120 V input	Channel 7
82	120 V input	Channel 8
14	n.c.	Channel 1
24	n.c.	Channel 2
34	n.c.	Channel 3
44	n.c.	Channel 4
54	n.c.	Channel 5
64	n.c.	Channel 6
74	n.c.	Channel 7
84	n.c.	Channel 8

Conductor cross-section

The minimum conductor cross-section for the terminal block X1 is 0.2mm² and the maximum is 2.5 mm².

8.2.5 Block diagram

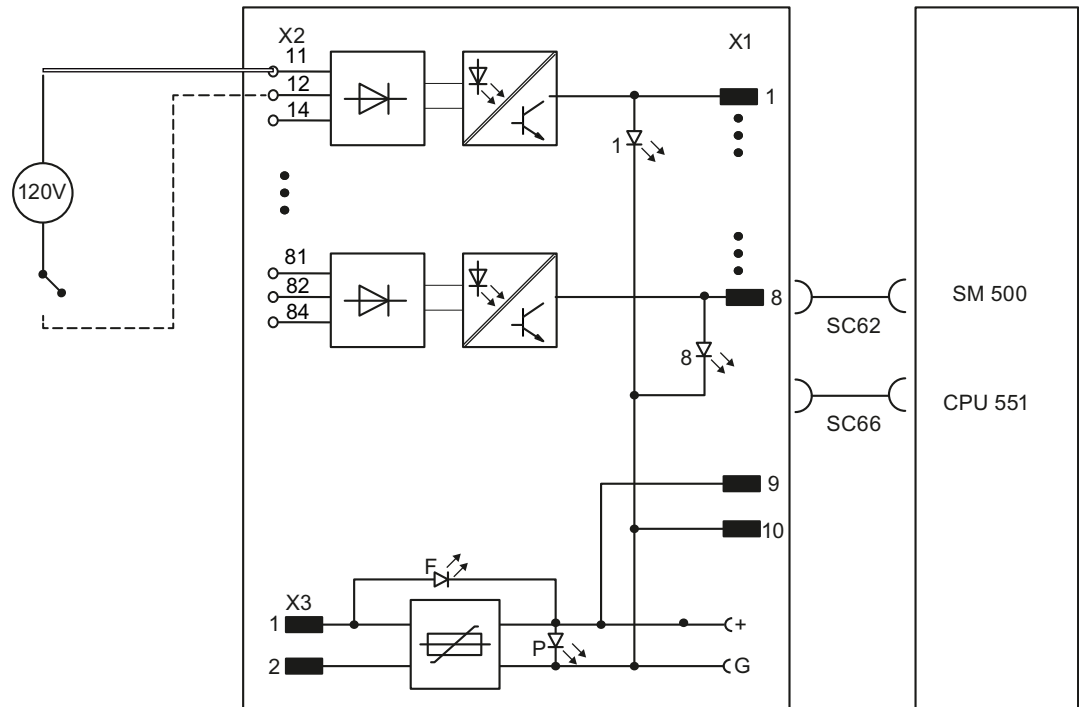

Figure 8-4 Block diagram of interface module SB60

8.3 Interface module SB61

Article number

6DD1681-0EB3

Description

Interface module SB61 is used to adapt 8 digital input signals with electrical isolation to the signal level of SIMATIC TDC components.

The cables SC62 or SC66 are used to connect the interface modules to the SIMATIC TDC components (for more information, refer to the SIMATIC TDC Documentation).

Module design

- Enclosure for snap-on mounting to rails
- Ribbon cable connector (X1):
 - 8 pins for digital outputs
 - 2 pins for 1P, 1M
- Connector (X2), 2 x 12-pole:
 - 8 terminals for 24 V digital inputs
 - 8 terminals for 48 V digital inputs
 - 8 terminals for reference potentials
- 1 terminal pair X3: 1P, 1M (voltage supply on SIMATIC TDC side)
- 1 terminal pair X4: 2P, 2M (voltage supply on plant side)
- Pin header for short-circuit plugs
- Double test socket X5:2P (+), 2M (G)
- LED displays for diagnostics
- Optocoupler for electrical isolation between inputs and outputs

Voltage supply on SIMATIC side

The SIMATIC TDC voltage supply is fed to terminal X3:

Terminal X3	Voltage on SIMATIC TDC side
1P	+24 V
1M	0 V

Connect the cables using accessory kit SM11 "Power supply connector for interface modules" (article number: 6DD1680-0BB0)

The maximum conductor cross-section at terminal X3 is 2.5 mm².

Green LED

The voltage supply (1P, 1M) on SIMATIC TDC-side is indicated by a green LED (P).

Red LED

The supply voltage on SIMATIC TDC-side (1P, 1M) is short-circuited (fault).

8.3.1 Signals

Voltage supply on plant side

24/48 V DC is available for the system side signals at terminal block X4:

Terminal X4	Voltage on plant side
2P 2M	+24/48 V 0 V

Connect the cables using accessory kit SM11 "Power supply connector for interface modules" (article number: 6DD1680-0BB0)

The maximum conductor cross-section at terminal X4 is 2.5 mm².

Test socket

The power supply for the plant/system side is available at double test socket X5 (G; +):

Double test socket X5	Voltage on plant side
+(2P of X4) G(2M of X4)	+24/48 V 0 V

 WARNING
Explosion hazard
It is not allowed to use the X5 test sockets in potentially explosive environments.

NOTE

When wiring the supply voltage, observe the "Installation and EMC Directives" chapter in the User Manual.

Yellow LED

The status of each of the eight signals is displayed by a yellow LED (1...8).

Terminal block for digital signals

There are three screw connections on terminal strip X2 for each signal:

- terminals 1 to 8 for 24 V binary signals
- terminals 11 to 18 for 48 V binary signals
- Terminals 51 to 58 for reference potential

8.3.2 Application notes

Plant/system-side signal voltages of 48V or 24V DC can be processed using the interface module. The plant/system side of the module has 8 electrically isolated input channels. Using short-circuit connectors (X11), the connection of each channel can be electrically isolated from one another, or connected to a common reference point:

Inputs, electrically isolated

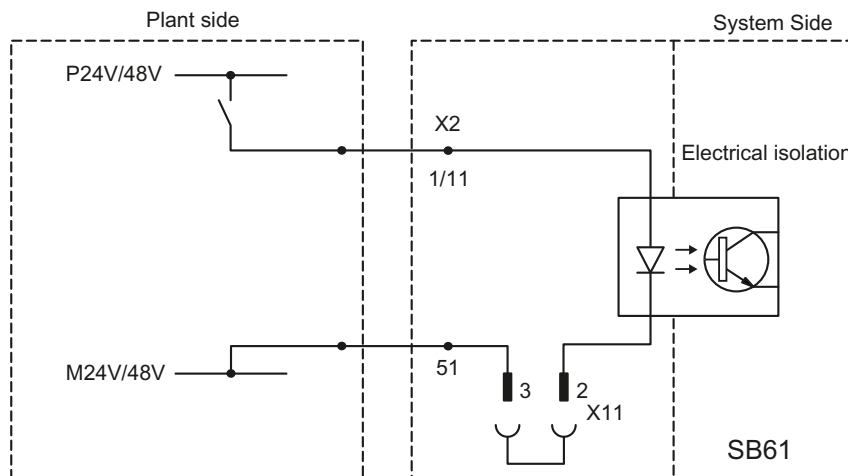

Figure 8-5 Position of the jumpers for electrically isolated inputs

Inputs with common reference potential

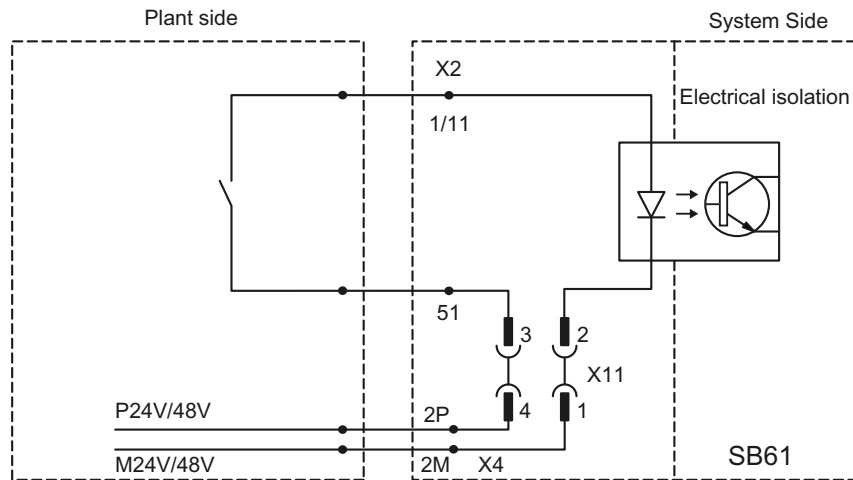

Figure 8-6 Position of the jumpers for inputs with common reference potential

CAUTION

All outputs have a common reference potential in delivery state, i. e. each terminal pair X11 to X18 is equipped with two short-circuit plugs.

Position of the jumpers

The jumpers (short-circuit plugs) are located in enclosure behind the lid section facing away from the LEDs. These are **only accessible after the interface module has been removed**.

The potential assignment between the plant and system side is defined as follows:

Table 8-3 Position of the short-circuit plug (jumper)

Reference potential of inputs	Position of the short-circuit plug (jumper)
The input circuits are additionally electrically isolated	Connector X1n ¹⁾ :2:3 inserted
Inputs with common reference potential	Connector X1n :1:2 and X1n :3:4 inserted
¹⁾ n = number of input 1 to 8	

NOTE

The **potential reference** can be set separately for each input.

The interface module is designed **only for vertical mounting positions** due to thermal losses to be dissipated.

Other information

For more information on EMC and environmental conditions, refer to section "General technical specifications (Page 41)"!

The following figure shows a typical application:

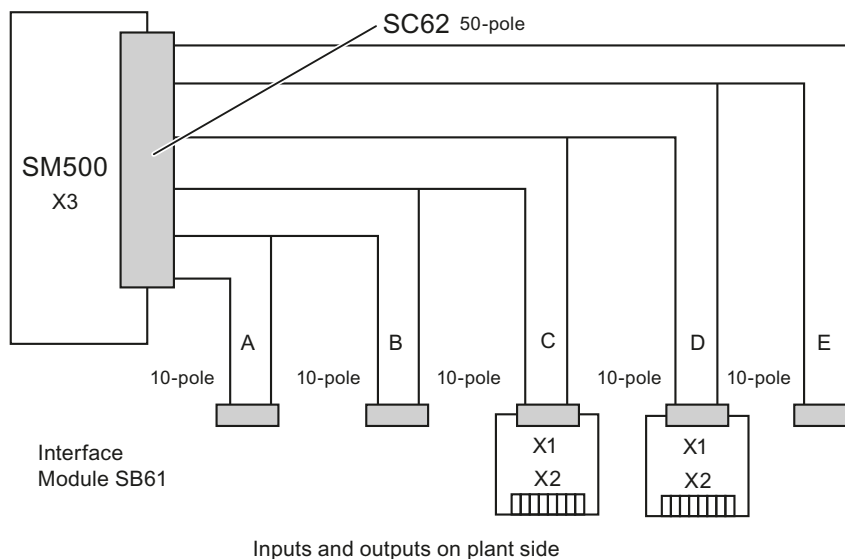

Figure 8-7 Application example of an SB61 interface module on digital I/O module SM500

8.3.3 Technical specifications

General data

Mounting system	The enclosure is suitable for snap-on mounting to rails
Dimensions W x H x D [mm]	45 x 129 x 160 mm
Weight	0.3 kg

Ambient temperatures

Ambient temperatures	max. 60 °C
----------------------	------------

Power supply

	SIMATIC TDC	Plant side 24 V DC	Plant side 48 V DC
Supply voltage (V_s)	DC 24 V	DC 24 V	DC 48 V
Valid range	20 V DC to 30 V DC	20 V DC to 30 V DC	40 V DC to 60 V DC
Briefly $t < 500$ ms	$1.5 \times V_{\text{rated}}$	$1.5 \times V_{\text{rated}}$	$1.5 \times V_{\text{rated}}$
Rated current consumption	90 mA	50 mA	50 mA

The maximum current of 1 A may not be exceeded on connector X3 if the supply of several terminal blocks is routed via this connector. The maximum current of 2 A may not be exceeded on connector X4 if the supply of several terminal blocks is routed via this connector.

Digital inputs

		Plant side 24 V DC	Plant side 48 V DC
Number		8	8
Input voltage for			
	'1 signal'	13 V DC to 30 V DC	26 V DC to 60 V DC
	'0 signal'	-3 V to +6 V ¹⁾	-3 V to +12 V ¹⁾
Input current ('1 signal')		6 mA	6 mA
¹⁾ or open-circuit input			

8.3.4 Pin assignment

Flat connector X1

Use cable SC62 and SC66 to connect the interface module to the SIMATIC TDC components (for further information, refer to the documentation for the SIMATIC TDC components).

Digital inputs, terminal block X2

Table 8-4 Pin assignment of the digital inputs of interface module SB61

Terminal	Inputs, electrically isolated	Inputs with common reference potential	Channel No.
1	+24 V input		Channel 1
2	+24 V input		Channel 2
3	+24 V input		Channel 3
4	+24 V input		Channel 4
5	+24 V input		Channel 5
6	+24 V input		Channel 6
7	+24 V input		Channel 7
8	+24 V input		Channel 8

Terminal	Inputs, electrically isolated	Inputs with common reference potential	Channel No.
11	+48 V input		Channel 1
12	+48 V input		Channel 2
13	+48 V input		Channel 3
14	+48 V input		Channel 4
15	+48 V input		Channel 5
16	+48 V input		Channel 6
17	+48 V input		Channel 7
18	+48 V input		Channel 8
51	Input 24 V/48 V	2P(+24 V)	Channel 1
52	Input 24 V/48 V	2P(+24 V)	Channel 2
53	Input 24 V/48 V	2P(+24 V)	Channel 3
54	Input 24 V/48 V	2P(+24 V)	Channel 4
55	Input 24 V/48 V	2P(+24 V)	Channel 5
56	Input 24 V/48 V	2P(+24 V)	Channel 6
57	Input 24 V/48 V	2P(+24 V)	Channel 7
58	Input 24 V/48 V	2P(+24 V)	Channel 8

Conductor cross-section

The minimum conductor cross-section for the terminal block X1 is 0.2mm² and the maximum is 2.5 mm².

8.3.5 Block diagram

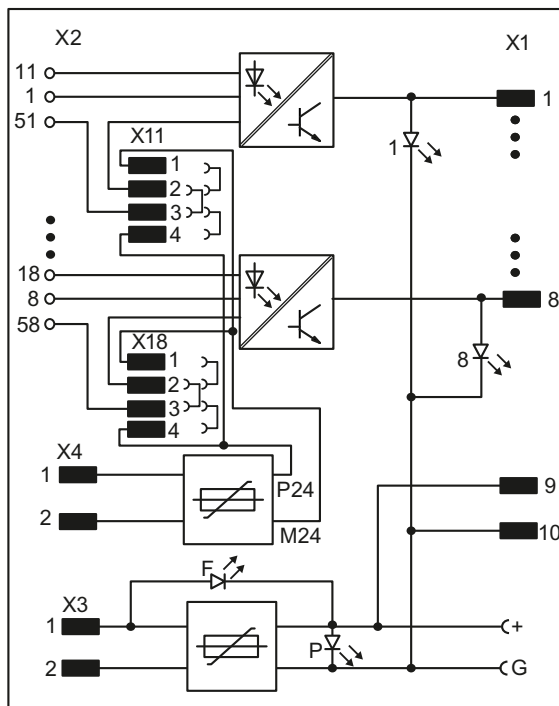

Figure 8-8 Block diagram of interface module SB61

8.4 Interface module SB70

Article number

6DD1681-0AG2

Description

Interface module SB70 is used to adapt eight digital output signals from SIMATIC TDC to the signal level of the plant by means of relay circuits.

The voltage of the output signal may amount up to max. 120 V DC or AC.

Cable SC62 is used to connect the interface module to the SIMATIC TDC components (for further information, refer to the documentation for the SIMATIC TDC components).

Module design

- Enclosure for snap-on mounting to rails
- Ribbon cable connector (X1):
 - 8 pins for digital inputs
 - 2 pins for 1P, 1M
- Connector (X2), 2 x 12-pole
 - 8 terminals for the NO contact
 - 8 terminals for the NC contact
 - 8 terminals for the center contact
- 1 terminal pair X3: 1P, 1M (voltage on SIMATIC TDC side)
- Double test socket X5: 1P(+), 1M(G)
- LED displays for diagnostics
- Relays for the electrical isolation of inputs and outputs
- PTC thermistor as line protection downstream of the voltage supply on SIMATIC side

Voltage supply on SIMATIC side

The SIMATIC TDC voltage supply is fed to terminal X3:

Terminal X3	Voltage on SIMATIC TDC side
1P 1M	+24 V 0 V

Connect the cables using accessory kit SM11 "Power supply connector for interface modules" (article number: 6DD1680-0BB0)

The maximum conductor cross-section at terminal X3 is 2.5 mm².

NOTE

When wiring the supply voltage, observe the "Installation and EMC Directives" chapter in the User Manual.



WARNING

Isolation

Safe electrical isolation is guaranteed only between the inputs and outputs

The system side (rack including 24V power supply) is safely isolated from hazardous voltages on plant side (8 output signals).

The output circuits are only isolated galvanically.

The output circuits on plant side are only isolated galvanically. Circuits consisting of combinations of safety extra-low voltage and hazardous voltages are not allowed.

Green LED

The voltage supply on SIMATIC TDC side is indicated by a green LED (P).

Red LED

The supply voltage on SIMATIC TDC side (1P, 1M) is short-circuited (fault).

Test socket

The SIMATIC TDC supply voltage is available on the double test socket X5 (G; +):

Double test socket X5	Voltage SIMATIC side
+ (1P of X3) G (1M of X3)	+24 V 0 V

8.4.1 Signals

Yellow LED

The status of each of the 8 signals (1...8) is displayed by means of a yellow LED.

Terminal block for digital signals

Terminal block X2 provides three screw terminals for each signal to the plant side:

- Terminals 14, 24 ... to 84 for NO contacts
- Terminals 12, 22 ... up to 82 for NC contacts

Terminals 11, 21 ... to 81 as center contact. The corresponding relay contacts are determined as follows:

Idle state	Connections (screw terminals)
Contact closed (NC contact)	n2 - n1 ¹⁾
Contact open (NO contact)	n4 - n1
¹⁾ n: 1...8, depending on the channel number	

NOTE

When wiring the signal voltage to the relay contacts, observe the "Installation and EMC Directives" chapter in the User Manual.

8.4.2 Application notes

The interface module is suitable for vertical and horizontal mounting positions

Other information

For more information on EMC and environmental conditions, refer to section "General technical specifications (Page 41)"!

The following figure shows a typical application:

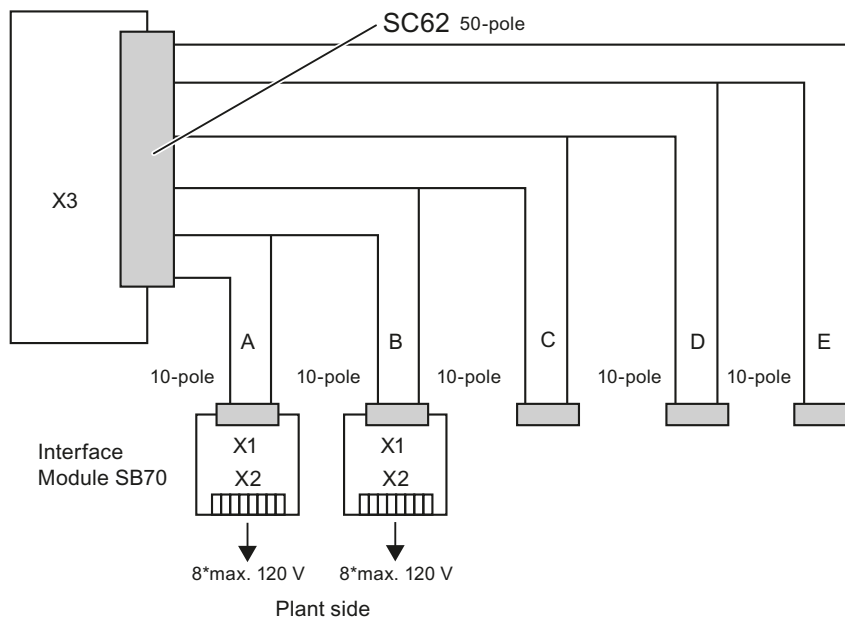

Figure 8-9 Application example of an SB70 interface module on digital I/O module SM500

The digital inputs of the interface module are connected via cable SC62 to the SIMATIC TDC outputs.

8.4.3 Technical specifications

General data

Mounting system	Housing can be snapped onto mounting rails
Dimensions W x H x D [mm]	45 x 129 x 160 mm
Weight	0.3 kg

Ambient temperatures

Ambient temperatures	max. 60 °C
----------------------	------------

Power supply

Rated supply voltage (V_s)	24 V DC
Valid range	20.4 V to 28.8 V DC
Briefly $t < 500$ ms	$1.5 \times V_{\text{rated}}$
Rated current consumption	150 mA

The maximum current of 1 A may not be exceeded on connector X3 if the supply of several terminal blocks is routed via this connector.

Digital outputs

Number	8	
Switching characteristics of the relay contacts		
	AC 120 V	2 A
	DC 120 V	0.4 A
	DC 60 V	1 A
	< DC 35 V	2 A
Switching frequency	Max. 20 Hz	
Dielectric strength	Safety isolation guaranteed: - between inputs and outputs Electrical isolation guaranteed: - between input circuits 1125 V AC test voltage	

8.4.4 Pin assignment

Flat connector X1

Use the SC62 cable to connect the interface module to the SIMATIC TDC components (for more information, refer to the SIMATIC TDC documentation).

Digital inputs, terminal block X2

Table 8-5 Pin assignment of the digital inputs of interface module SB70, terminal block X2

Terminal	120 V	Channel No.
11	Center contact	Channel 1
21	Center contact	Channel 2
31	Center contact	Channel 3
41	Center contact	Channel 4
51	Center contact	Channel 5
61	Center contact	Channel 6
71	Center contact	Channel 7

Terminal	120 V	Channel No.
81	Center contact	Channel 8
12	NC contact	Channel 1
22	NC contact	Channel 2
32	NC contact	Channel 3
42	NC contact	Channel 4
52	NC contact	Channel 5
62	NC contact	Channel 6
72	NC contact	Channel 7
82	NC contact	Channel 8
14	NO contact	Channel 1
24	NO contact	Channel 2
34	NO contact	Channel 3
44	NO contact	Channel 4
54	NO contact	Channel 5
64	NO contact	Channel 6
74	NO contact	Channel 7
84	NO contact	Channel 8

Conductor cross-section

The minimum conductor cross-section for the terminal block X1 is 0.2mm² and the maximum is 2.5 mm².

8.4.5 Block diagram

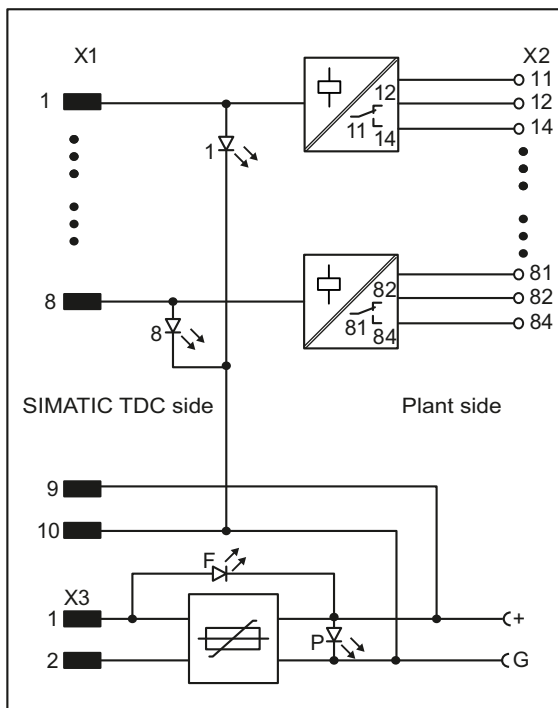

Figure 8-10 Block diagram of interface module SB70

8.5 Interface module SB71

Article number

6DD1681-0DH1

Description

Interface module SB71 is used to adapt eight digital DC signals from SIMATIC TDC to the signal level on plant side in an electrically isolated circuit.

Cable SC62 is used to connect the interface module to the SIMATIC TDC components (for further information, refer to the documentation for the SIMATIC TDC components).

Module design

- The enclosure is suitable for snap-on mounting to rails
- Ribbon cable connector (X1):
 - 8 pins for digital inputs
 - 2 pins for 1P, 1M
- Connector (X2), 2x 8-pole
 - 8 terminals for digital outputs, 24/48 V DC
 - 8 terminals for reference potentials
- 1 terminal pair X3: 1P and 1M (voltage supply on SIMATIC TDC side)
- 1 terminal pair X4: 2P, 2M (voltage supply on plant side)
- Double test socket X5: 1P(+), 1M(G)
- LED displays for diagnostics
- Optocoupler for electrical isolation between inputs and outputs

Voltage supply on SIMATIC side

The SIMATIC TDC voltage supply is fed to terminal X3:

Terminal X3	Voltage on SIMATIC TDC side
1P	+24 V
1M	0 V

Connect the cables using accessory kit SM11 "Power supply connector for interface modules" (article number: 6DD1680-0BB0)

The maximum conductor cross-section at terminal X3 is 2.5 mm².

Green LED

The voltage supply on SIMATIC TDC side is indicated by a green LED (P).

Red LED

The supply voltage on SIMATIC TDC side (1P, 1M) is short-circuited (fault).

Voltage supply on plant side

The 24/48 V DC power supply voltage for signals on plant side is wired to terminal block X4:

Terminal X4	Voltage on plant side
2P	+24/48 V
2M	0 V

Connect the cables using accessory kit SM11 "Power supply connector for interface modules" (article number: 6DD1680-0BB0)

The maximum conductor cross-section at terminal X4 is 2.5 mm².

Test socket

The SIMATIC TDC supply voltage is available on the double test socket X5 (G; +):

Double test socket X5	Voltage SIMATIC side
+ (1P of X3)	+24 V
G (1M of X3)	0 V

⚠ WARNING**Explosion hazard**

It is not allowed to use the X5 test sockets in potentially explosive environments.

NOTE

When wiring the supply voltage, observe the "Installation and EMC Directives" chapter in the User Manual.

8.5.1 Signals

Yellow LED

The status of each of the eight signals is displayed by a yellow LED (1...8).

Terminal block for digital signals

Terminal block X2 provides two screw terminals for each signal:

- Terminals 1 to 8 for digital outputs, 24/48 V DC
- Terminals 51 to 58 for reference potential

8.5.3 Technical specifications

General data

Mounting system	The enclosure is suitable for snap-on mounting to rails
Dimensions W x H x D [mm]	45 x 129 x 160 mm
Weight	0.3 kg

Ambient temperatures

Ambient temperatures	max. 60 °C
----------------------	------------

Power supply

	SIMATIC TDC	Plant side 24 V DC	Plant side 48 V DC
Supply voltage (V_s)	DC 24 V	DC 24 V	DC 48 V
Valid range	20.4 V to 28.8 V DC	18 V DC to 60 V DC	18 V DC to 60 V DC
Briefly $t < 500$ ms	$1.5 \times V_{rated}$	$1.5 \times V_{rated}$	$1.5 \times V_{rated}$
Rated current consumption	55 mA	300 mA	360 mA

The maximum current of 1 A may not be exceeded on connector X3 if the supply of several terminal blocks is routed via this connector. The maximum current of 2 A may not be exceeded on connector X4 if the supply of several terminal blocks is routed via this connector.

Digital outputs

	Plant side 24 V DC	Plant side 48 V DC
Number	8	8
Output voltage for '1 signal'		
at 0 mA output current	($V_s - 0.6$ V)	($V_s - 1.2$ V)
at 20 mA output current	($V_s - 2.1$ V)	($V_s - 2.0$ V)
at 30 mA output current	($V_s - 2.7$ V)	($V_s - 2.9$ V)
Output voltage for '0 signal'	0 V	0 V
Max. output current (for '1 signal')	30 mA	30 mA

The digital outputs are sustained short circuit-proof.

8.5.4 Pin assignment

Flat connector X1

Cable SC62 is used to connect the interface module to the SIMATIC TDC components (for further information, refer to the documentation for the SIMATIC TDC components).

Digital outputs, terminal strip X2

Table 8-6 Pin assignment of the digital outputs of interface module SB71

Terminal	Designation
1	Digital output 1
2	Digital output 2
3	Digital output 3
4	Digital output 4
5	Digital output 5
6	Digital output 6
7	Digital output 7
8	Digital output 8
51	0 V, digital output 1
52	0 V, digital output 2
53	0 V, digital output 3
54	0 V, digital output 4
55	0 V, digital output 5
56	0 V, digital output 6
57	0 V, digital output 7
58	0 V, digital output 8

Conductor cross-section

The minimum conductor cross-section for the terminal block X1 is 0.2mm² and the maximum is 2.5 mm².

8.5.5 Block diagram

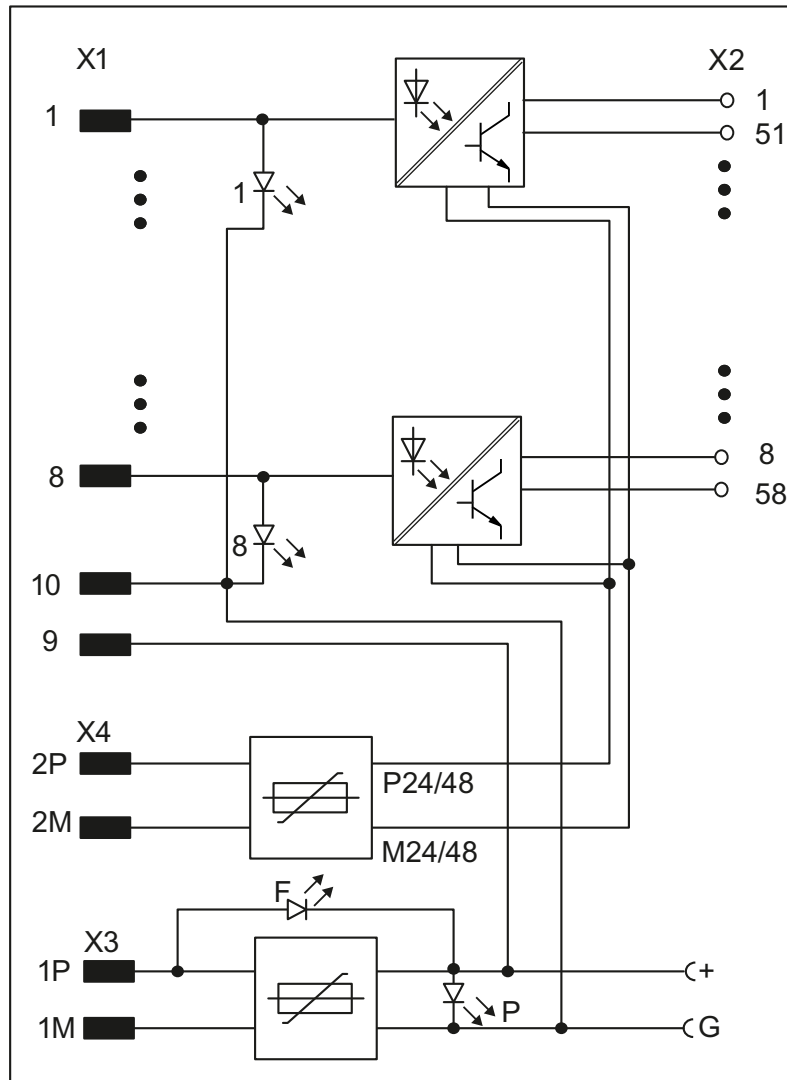

Figure 8-12 Block diagram of interface module SB71

8.6 Interface modules SU12 und SU13

Article number

SU12	6DD1681-0AJ1
SU13	6DD1681-0GK0

General

SU12	SU13
Interface module SU12 is a 10-pin joint block. This is used to connect analog or binary signals of a 10-pin ribbon cable connector (SIMATIC side) to spring terminals (plant side).	Interface module SU13 is a 50-pin joint block. that is used to wire 50 signals routed via a 50-pole connector (SIMATIC side) to screw terminals (plant side).

Module design

SU12	16 spring-loaded terminals (X2) 10 spring-loaded terminals for analog or digital signals on plant side 6 unused spring-loaded terminals 10-pole connectors X1.
SU13	50 screw terminals (X2) Connection of 50 signals 50-pole connector X1.

8.6.1 Function description

Interface modules SU12 and SU13 are used to wire a ribbon cable connector X1 on SIMATIC TDC side 1:1 to the terminal blocks X2 on plant side, with the exception of the following terminals.

The following signal lines are fused at the terminals (0.5 A slow-blow, internal resistance 0.25 Ω):

Interface module	Terminal block X2
SU12	Pin 1 – 8
SU13	Pin 8, 17 – 23, 26 – 33, 36 – 43, 46 – 48

The following terminals have a protective diode (Schottky diode type Vishay BAT46) for the 24 V supply voltage of digital outputs in the following signal lines:

Interface module	Terminal block X2
SU12	Pin 10
SU13	Pin 10

A PTC resistor (internal resistance: 0.9 Ω , e.g. type Epcos B59910-C120-A70) element is installed at the following terminals for short-circuit protection of the 24 V supply voltage of digital outputs in the signal line:

Interface module	Terminal block X2
SU12	Pin 9
SU13	Pin 9

Process signals

The concept of the interface modules support signal flow on both sides. The process signals are transferred without additional electrical isolation and signal preparation.

Table 8-7 Maximum permissible voltage and current values for signal processing

Voltage range	The maximum permitted voltages of the modules to which the interface modules are connected must be maintained.
Current range	Max. 0.5 A

8.6.2 Additional components

Cables for:

The following cables are required to wire the interface modules to the modules:

SU12

Table 8-8 Modules and signal cables as additional components for SU12

Cable	Modules	Connectors
SC62	SM500	X3
SC66	CPU551	X2

SU13

Table 8-9 Modules and signal cables as additional components for SU13

Cable	Modules	Connectors
SC63	SM500	X1, X2, X3
	CP52M0	X6

8.6.3 Application notes

The interface modules are suitable for **vertical and horizontal** mounting positions. The modules must be installed on mounting rails.

Other information

For more information on EMC and environmental conditions, refer to section "General technical specifications ([Page 41](#))"

8.6.4 Pin/terminal assignment X1/X2

The screw terminal numbers of X2 are identical with the numbering of ribbon cable connector in accordance with the pin counting mode.

Conductor cross-sections

Interface module	Minimum conductor cross-section on terminal block X2	Maximum conductor cross section on terminal block X2
SU12	0.2 mm ²	2.5 mm ² .
SU13	0.2 mm ²	1.5 mm ² .

SU12

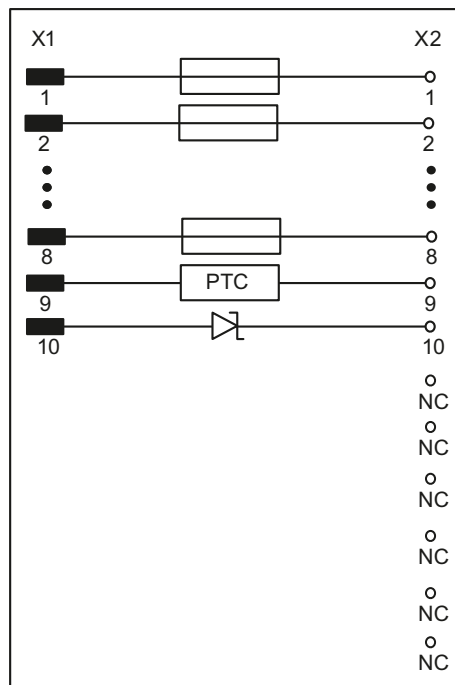

Figure 8-13 SU12 circuit diagram

The components are described in chapter Function description [\(Page 203\)](#).

SU13

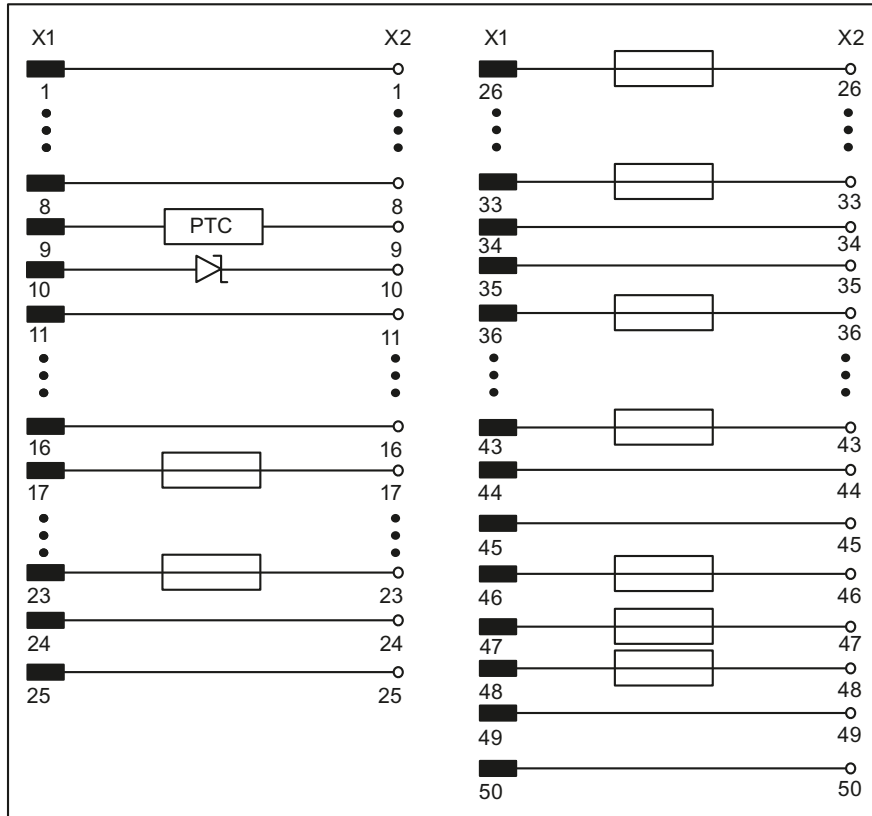

Figure 8-14 SU13 circuit diagram

The components are described in chapter Function description (Page 203).

8.6.5 Technical specifications

General data

Dimensions W x H x D [mm]	45 x 129 x 160 mm
Weight	0.3 kg

Ambient temperatures

Ambient temperatures	max. 60 °C
----------------------	------------

Submodules

9.1 Program memory modules CPU555

Article number

Program memory (2 MB)	6ES7953-8LL31-0AA0
Program memory (4 MB)	6ES7953-8LM31-0AA0
Program memory (8 MB)	6ES7953-8LP31-0AA0

Description

The program memory modules are used to store the processor program (including the operating system) you configured in HW Config and CFC and for saving online changes.

Installation/ programming

The program memory module is inserted into the submodule slot X4 provided on the CPU555 module and can be loaded with the user program in various ways:

- **Offline loading**
 - By means of an MMC card reader integrated in the "Field PG"
 - Via a SIMATIC USB prommer (6ES7792-0AA00-0XA0) connected via USB to the PC
- **Online download**
 - Directly from the PC via a communication link (e.g. PROFINET) into the memory module plugged into the CPU555 module.

Program size

The volume of configuration data to download to the memory module (compressed to approx. 50 %) and the free program memory space can be viewed in the CFC by selecting:
PLC / Load / Info

Memory overview

The following table shows the differences in the expansion of the program memory modules:

Application	S7 MMC		
	6ES7953-8LL31-0AA0	6ES7953-8LM31-0AA0	6ES7953-8LP31-0AA0
Flash memory for storing the configuration and variable operating parameters	2 MB	4 MB	8 MB

Flash memory is non-volatile and can be electrically programmed and erased.

Dimensions

Dimensions W x H x D [mm]	24 x 1.4 x 32
Weight	0.1 kg

9.2 Program memory modules CPU550/551

Article number

Program memory module MC500	6DD1610-0AH4
Program memory module MC510	6DD1610-0AH6
Program memory module MC521	6DD1610-0AH3

Description

The program memory modules are used to store the processor program (including the operating system) you configured in HW Config and CFC.

Installation/ programming

The program memory module is inserted into the submodule slot provided on the CPU module and can be loaded with the user program in two ways:

- By means of an integrated PCMCIA ("PC Card") programming adapter on the PC (**loading in offline mode**)
- Directly from the PC to the memory module inserted in the CPU module via serial communication connection (**download in online mode**)

Program size

The volume of configuration data to download to the memory module (compressed to approx. 50 %) and the free program memory space can be viewed in the CFC by selecting:
PLC / Load / Info

Memory overview

The following table shows the differences in the application and expansion of the program memory modules:

Application	MC521	MC500	MC510
Flash memory for storing the configuration data	2 MB	4 MB	8 MB
EEPROM for variable operating parameters	8 KB	8 KB	8 KB

Flash memory is non-volatile and can be electrically programmed and erased.

Dimensions

Dimensions W x H x D [mm]	54 x 85.6 x 3.3 mm
Weight	0.1 kg

Index

- A**
- Approvals, [15](#)
 - CE, [16](#)
 - cULus, [17](#)
 - FM, [18](#)
- ATEX approval, [18](#)
- C**
- CE approval, [16](#)
- Connection via interface module, [37](#)
- Connector X1, [38](#)
- CP50M1
 - Areas of application for communication module CP50M1, [124](#)
 - Control and display elements, [125](#)
 - Status and fault displays, [126](#)
 - Application notes and immunity to interference, [127](#)
 - Additional components, [128](#)
 - Pin assignments, [128](#)
 - Technical specifications/performance features, [129](#)
- CP51M1
 - Areas of application for communication module CP51M1, [131](#)
 - Control and display elements, [132](#)
 - Status and fault displays, [133](#)
 - Application notes and immunity to interference, [134](#)
 - Additional components, [135](#)
 - Pin assignments, [135](#)
 - Technical specifications/performance features, [136](#)
- CP52A0
 - Control and display elements, [156](#)
 - Status and fault displays, [157](#)
 - Application notes and immunity to interference, [158](#)
 - Additional components, [159](#)
 - Pin assignments, [160](#)
 - Technical specifications/performance features, [160](#)
- CP52IO
 - Control and display elements, [150](#)
 - Status and fault displays, [151](#)
 - Application notes and immunity to interference, [152](#)
 - Additional components, [153](#)
 - Pin assignments, [154](#)
 - Technical specifications/performance features, [154](#)
- CP52M0
 - Control and display elements, [139](#)
 - Status and fault displays, [140](#)
 - Application notes and immunity to interference, [142](#)
 - Additional components, [145](#)
 - Pin assignments, [145](#)
 - Technical specifications/performance features, [147](#)
- CP53M0
 - Areas of application of coupling module P53M0, [161](#)
 - Control and display elements, [164](#)
 - Status and fault displays, [165](#)
 - Application notes and immunity to interference, [167](#)
 - Additional components, [168](#)
 - Pin assignments, [169](#)
 - Technical specifications/performance features, [169](#)
- CPU550/551
 - Areas of application, [88](#)
 - Control and display elements, [90](#)
 - Status and fault displays, [91](#)
 - Application notes and immunity to interference, [93](#)
 - Additional components, [94](#)
 - Pin assignments, [94](#)
 - Technical specifications/performance features, [95](#)

CPU555

- Areas of application , [76](#)
- Control and display elements , [77](#)
- Status and fault displays , [78](#)
- Application notes and immunity to interference , [81](#)
- Additional components , [82](#)
- Pin assignments , [83](#)
- Technical specifications/performance features , [85](#)

CPU module CPU550/ 551 , [88](#)

CPU module CPU555 , [76](#)

cULus approval, [17](#)

E

Environmental conditions, [41](#)

F

Fire protection, [22](#)

FM approval, [18](#)

G

- GlobalDataMemory CP52A0
CP52A0 GDM access module, areas of application for CP52A0 , [155](#)
- GlobalDataMemory CP52IO
CP52IO GDM interface module, areas of application for CP52IO , [149](#)
- GlobalDataMemory CP52M0
CP52M0 GDM memory module, areas of application for CP52M0 , [138](#)

I

IECEX approval, [19](#)

M

MC500, MC510, MC521 program memory modules, [208](#)

S**SB10**

- Description of interface module SB10, [171](#)
- Signals, [173](#)
- Application notes, [174](#)
- Technical specifications, [174](#)
- Digital signals, [175](#)

SB60

- Description of interface module SB60, [177](#)
- Pin assignment, [177](#)
- Application notes, [179](#)
- Technical specifications, [179](#)
- Digital inputs, [180](#)
- Pin assignment, [180](#)

SB61

- Description of interface module SB61, [182](#)
- Test socket, [183](#)
- Pin assignment, [184](#)
- Application notes, [184](#)
- Technical specifications, [186](#)
- Digital inputs, [187](#)
- Pin assignments, [187](#)

SB70

- Description of interface module SB70, [189](#)
- Application notes, [192](#)
- Technical Data, [192](#)
- Digital outputs, [193](#)

SB71

- Description of interface module SB71, [195](#)
- Test socket, [196](#)
- Application notes, [198](#)
- Technical specifications, [199](#)
- Digital outputs, [199](#)
- Pin assignments, [200](#)

SIMADYN D Technical Specifications

- Installation and EMC guidelines, [13](#)

Slot covers , [75](#)

SM500

- Areas of application of signal module SM500 , [100](#)
- Control and display elements , [100](#)
- Status and fault displays , [101](#)
- Application notes and immunity to interference , [102](#)
- Additional components , [103](#)
- Incremental encoder settings , [104](#)
- Pin assignments , [105](#)
- Technical specifications/performance features , [110](#)

SM500 DI/DQ, [115](#)

Standards, [15](#)

SU10, SU11, and SU12

Process signals, [203](#)

SU10, SU11, SU12, and SU13

General, [202](#)

Function description, [203](#)

Additional components, [204](#)

Application notes, [204](#)

SU10, SU11, SU12 and SU13
SU10, SU11, SU12 and SU13

Terminal/pin assignment, [205](#)

SU12

Technical Data, [206](#)

SU13

Technical Data, [206](#)

T

Technical specifications

Introduction, [14](#)

Standards and Approvals, [15](#)

Input of external voltages, [21](#)

Installation clearances, [25](#)

Equipotential bonding, [26](#)

Protective ground, [32](#)

Power supply, [34](#)

Rack, [35](#)

ESD, [38](#)

Shipping modules, [40](#)

U

UR5213

Areas of application for rack UR5213 , [57](#)

PS5213, mechanical layout , [58](#)

Control and display elements , [59](#)

Status and fault displays , [60](#)

Power supply , [60](#)

Voltage monitoring , [61](#)

Battery backup , [63](#)

Fan monitoring , [64](#)

Fan monitoring , [65](#)

Technical specifications , [66](#)

Areas of application for rack UR5213, [68](#)

PS5213, mechanical layout, [69](#)

Control and display elements, [69](#)

Status and fault displays, [70](#)

Power supply, [71](#)

Voltage monitoring, [71](#)

Battery backup, [72](#)

Fan monitoring, [73](#)

Technical specifications, [74](#)

UR6021

Areas of application for rack UR6021, [43](#)

PS6021, mechanical layout, [44](#)

Control and display elements, [45](#)

Status and fault displays, [46](#)

Power supply , [47](#)

Voltage monitoring, [48](#)

Battery backup, [50](#)

Fan monitoring , [51](#)

Fan monitor , [52](#)

Technical specifications, [55](#)